

Cable Pulling

Greenlee offers high-quality and durable cable pulling equipment designed to get the job done. From simple, straight shots to pulls with multiple bends and offsets, having Greenlee's cable pullers on the jobsite is a sure way to make your job faster, safer and easier in any application.

Contents

Cable Feeders	146
Lubrication Systems	147
Cable Tuggers	148
Tugger Accessories	158
Sheaves	160
Cable Tray Accessories	164
Rope	166
Lubricants	167
Swabs, Brushes, Mandrels & Swivels	169
Grips	172



GREENLEE[®]
A Textron Company

MADE FOR THE TRADE![™]



ULTRA FEEDER

Ultra Cable Feeder[™]



- Feeds cable at variable speeds to match the speed of cable puller.
- Accommodates cable ranging in size up to 3.5" (88.9 mm) in diameter.
- Now with new tires for improved traction with low friction cables.
- Sets up easily and can be operated by just one person.
- Dual motors drive each wheel for traction on both sides of the cable.
- Comes with pendant and toggle switch. An optional foot switch is available to control feeding.
- Two cable loading methods: top-loading and end-loading.
- Patented.

CAT. NO.	UPC NO.	DESCRIPTION
----------	---------	-------------

6810	05564	Ultra Cable Feeder with Hand Switch 120V
IN 6810-22	12293	Ultra Cable Feeder with Hand Switch 220V
445	24821	A Foot Switch
05645	05645	B Tee (included)

SPECIFICATIONS

Power Supply 115 VAC, 15 amps, 60 Hz
230 VAC, 8 amps, 50/0 Hz

Speed 4-36 feet per minute
(1.2-11 meters per minute)

Maximum Tractive Force Single Cable: 200 lbs. (.9 kN)
All Cables: 800 lbs. (3.5 kN)

Cable Capacity	Quantity	Size
	8 x	250 MCM (120 mm ²)
	6 x	500 MCM (240 mm ²)
	5 x	750 MCM (300 mm ²)

Reel Weight Capacity 25,000 lbs. total (11,300 kg)

Size 41" long x 27.5" wide x 37.5" high
(1040 mm x 699 mm x 953 mm)

Weight 285 lbs. (130 kg)

Tire Pressure 50psi (2.4 bar)

Cable Pulling

INTERNATIONAL

Tel: +1.815.397.7070
Fax: +1.815.397.9247

CANADA

Tel: 800.435.0786
Fax: 800.524.2853

USA

Tel: 800.435.0786
Fax: 800.451.2632

UG5 Ultra GLIDER™ Cable Pulling Lubrication System



The Greenlee UG5 Ultra Glider™ is the “new way” to effectively apply cable lube during cable installation. The Ultra GLIDER™ has several advantages over the manual method used by most contractors today.

- Applies lube more evenly around the cable and more consistently than can be done by hand. This reduces the force required by the cable puller and reduces the chance for damage to the cable.
- During a cable pull, the person feeding the cable usually can also operate the Ultra GLIDER™, which reduces the need for one person on the job.
- Eliminates the need for a person to place their hands near the point where the cable enters the conduit or duct.
- Eliminates the mess and slippery surfaces associated with manual cable lubrication.
- Applicators clean easily with water. Power unit and hose do not require cleaning between jobs.
- 3 pump speeds make it easy to match the lube rate to the needs of the pull.

CAT. NO.	UPC NO.	DESCRIPTION
UG511S	10353	ULTRA-GLIDER 120V with UGSAK slip-in applicator kit
UG511T	10355	ULTRA-GLIDER 120V with UGTAK threaded applicator kit
UG511ST	10356	ULTRA-GLIDER 120V including slip-in applicator kit UGSAK & threaded applicator kit UGTAK
UG512S	10357	ULTRA-GLIDER 12V with UGSAK slip-in applicator kit
UG512T	10359	ULTRA-GLIDER 12V with UGTAK threaded applicator kit
UG512ST	10360	ULTRA-GLIDER 12V including slip-in applicator kit UGSAK & threaded applicator kit UGTAK
UG511	10354	ULTRA-GLIDER 120V ASSEMBLY without applicators
UG512	10358	ULTRA-GLIDER 12V ASSEMBLY without applicators
UGSAK	10252	Slip-In Applicator Kit (Includes 2", 2-1/2", 3", 3-1/2" and 4" applicators with case)
UGTAK	10253	Threaded Applicator Kit (Includes 2", 2-1/2", 3", 3-1/2" and 4" applicators with case)
UGSA150	10287	A 1-1/2" Slip-In Applicator Assembly
UGSA200	10289	A 2" Slip-In Applicator Assembly
UGSA250	10291	A 2-1/2" Slip-In Applicator Assembly
UGSA300	10293	A 3" Slip-In Applicator Assembly
UGSA350	10295	A 3-1/2" Slip-In Applicator Assembly
UGSA400	10297	A 4" Slip-In Applicator Assembly
UGSA500	10304	A 5" Slip-In Applicator Assembly
UGSA600	10311	A 6" Slip-In Applicator Assembly
UGTA075	10284	A 3/4" Threaded Applicator Assembly
UGTA100	10285	A 1" Threaded Applicator Assembly
UGTA125	10286	A 1-1/4" Threaded Applicator Assembly
UGTA150	10278	A 1-1/2" Threaded Applicator Assembly
UGTA200	10279	A 2" Threaded Applicator Assembly
UGTA250	10280	A 2-1/2" Threaded Applicator Assembly
UGTA300	10281	A 3" Threaded Applicator Assembly
UGTA350	10282	A 3-1/2" Threaded Applicator Assembly
UGTA400	10283	A 4" Threaded Applicator Assembly
12656	12656	A 20' Extension Hose (MAXIMUM EXTENSION IS 20')

SPECIFICATIONS

Dimensions	Depth: 17" (0.43 m) Width: 18" (0.45 m) Height: 39" (1 m)
Weight	24 lbs. (11 kg)
Wheel Diameter	8" (20 cm)
Hose length	10' (3 m)
Battery (12V unit only)	Type: Sealed lead acid rechargeable battery DC output: 12-Volt Weight: 14.5 lbs. (6.6kg) Battery Life: Three to four 5 gallon buckets per charge
Motor (120V unit only)	AC output: 120-Volt Amps: 6 Amps

Cable Pulling

USA

Tel: 800.435.0786
Fax: 800.451.2632

CANADA

Tel: 800.435.0786
Fax: 800.524.2853

INTERNATIONAL

Tel: +1.815.397.7070
Fax: +1.815.397.9247



CABLE PULLERS

Cable Puller Selection Guide

CAT. NO.	DESCRIPTION	PAGE NO.	PULLING FORCE			SPEED						POWER	REQUIRED ROPE	
			CONTINUOUS	MAXIMUM	WEIGHT	NO LOAD	800 LBS	2000 LBS	4000 LBS	5000 LBS	6000 LBS			8000 LBS
6800	Ultra Tugger™ 8 Power Cable Puller	152	6500 lbs.	8000 lbs.	86 lbs.	9 fpm		3.0 fpm	7.5 fpm		7.0 fpm	6.0 fpm	1-1/2 HP electric	7/8" double braid
6501	Ultra Tugger™ 5 Power Cable Puller	153	4000 lbs.	5000 lbs.	84 lbs.	14.5 fpm			11.0 fpm	9.5 fpm			1-1/2 HP electric	3/4" double braid
6001	Super Tugger® Power Cable Puller	154	4500 lbs.	6500 lbs.	108 lbs.	16.5 fpm		11.0 fpm	7.5 fpm	6.0 fpm			1-1/2 HP electric	3/4" double braid
UT4	Ultra Tugger® 4 Power Cable Puller	155	3000 lbs.	4000 lbs.	175 lbs.	26/13 fpm		20.0 fpm	10.0 fpm				1-1/4 HP electric	9/16" double braid
UT2	Ultra Tugger® 2 Power Cable Puller	156	2000 lbs.	2000 lbs.	67 lbs.	73/41 fpm	36.0 fpm	22.0 fpm					1 HP electric	9/16" double braid
766	Hand Crank Wire Puller	157		1500 lbs.	35 lbs.									†

† - 766 comes with 200 ft. of aircraft-type steel swaged cable.



6800



6501



6001



UT4



UT2



766

Cable Pulling

INTERNATIONAL

Tel: +1.815.397.7070
Fax: +1.815.397.9247

CANADA

Tel: 800.435.0786
Fax: 800.524.2853

USA

Tel: 800.435.0786
Fax: 800.451.2632

Cable Puller Set-Up (UT8, UT5, 6001)



The Versi-Boom™ Plus System can reach into a man-hole, yet allow the operator to run the puller from above.

The equipment used is included in 6805A, 6805A-22, 6805B, 6805B-22, 6505, 6505-22 and 6005.



Operator is making an upward pull from the box using the puller and Versi-Boom System attached to the mobile carriage.

The equipment used is included in packages 6805A, 6805A-22, 6805B, 6805B-22, 6505, 6505-22, 6503, 6005 and 6004. Rope is not included.



Operator is making a downward pull from the box using the puller with the chain mount (or vise chain unit) mounted onto the conduit.

The equipment used is included in packages 6801, 6501, 6501-22, 6005, 6004, 6001 and 6001-22. Rope is not included.



Operator is making an upward pull from the box using the puller and Versi-Boom System attached to the "T" stand.

The "T" stand is an optional accessory for use with the 6803, 6803B, 6805A, 6805B, 6805A-22, 6805B-22, 6503, 6505 and 6505-22. Rope is not included.



Operator is making a downward pull from the box using the puller with the floor mount anchored to the floor.

The equipment used is included in packages 6805A, 6805A-22, 6805B, 6805B-22, 6802, 6802-22, 6800, 6800-22, 6505, 6505-22, 6005 and 6004. Rope is not included.



Operator is making an upward pull from the box using the puller and Versi-Boom Plus System attached to the mobile carriage.

The equipment used is included in packages 6805A, 6805A-22, 6805B, 6805B-22, 6505, 6505-22, and 6005. Rope is not included.

Cable Pulling

USA

Tel: 800.435.0786
Fax: 800.451.2632

CANADA

Tel: 800.435.0786
Fax: 800.524.2853

INTERNATIONAL

Tel: +1.815.397.7070
Fax: +1.815.397.9247

Package Components

Cable Pulling

Cat. No.	UPC No.	Description	Ultra Tugger 8 - 8,000 lb						Ultra Tugger 5 - 5,000 lb								
			110 VAC			220 VAC			110 VAC			220 VAC					
			6800	6801	6803	6803B	6805A	6805B	6800-22	6805A-22	6805B-22	6500	6501	6503	6505	6500-22	6501-22
08000	08000	Ultra Tugger 8 w/ force gauge 120 VAC 60 Hz	✓	✓	✓	✓	✓	✓									
UT8-22	07924	Ultra Tugger 8 w/ force gauge 220 VAC 50 Hz							✓	✓	✓						
15000	15000	Ultra Tugger 5 w/ force gauge 120 VAC 60 Hz										✓	✓	✓	✓		
UT5-22	07924	Ultra Tugger 5 w/ force gauge 120 VAC 60 Hz													✓	✓	✓
00865	00865	Floor Mount	✓					✓	✓	✓	✓			✓	✓		✓
02846	02846	Chain Mount		✓								✓			✓		
00870	00870	Wheeled Carriage			✓	✓	✓	✓		✓	✓		✓	✓			✓
00871	00871	Boom Mount			✓	✓	✓	✓		✓	✓		✓	✓			✓
00864	00864	Nose Unit			✓	✓	✓	✓		✓	✓		✓	✓			✓
00863	00863	Elbow Unit					✓	✓		✓	✓		✓				✓
00835	00835	3' (.9 m) Boom Tube					✓	✓		✓	✓		✓				✓
00791	00791	4' (1.2 m) Boom Tube			✓	✓	✓	✓		✓	✓		✓	✓			✓
00781	00781	2-1/2" Screw-On Coupling			✓	✓	✓	✓		✓	✓		✓	✓			✓
00782	00782	3" Screw-On Coupling			✓	✓	✓	✓		✓	✓		✓	✓			✓
00784	00784	4" Screw-On Coupling			✓	✓	✓	✓		✓	✓		✓	✓			✓
00799	00799	Adapter for Screw-On Coupling			✓	✓	✓	✓		✓	✓		✓	✓			✓
00804	00804	2-1/2" Slip-In Coupling			✓	✓	✓	✓		✓	✓		✓	✓			✓
00811	00811	3" Slip-In Coupling			✓	✓	✓	✓		✓	✓		✓	✓			✓
00820	00820	4" Slip-In Coupling			✓	✓	✓	✓		✓	✓		✓	✓			✓
11152	11152	Storage Trays (2)			✓	✓	✓	✓		✓	✓		✓	✓			✓
3048	23362	Storage Box				✓		✓		✓							
603	23405	Casters				✓		✓		✓							

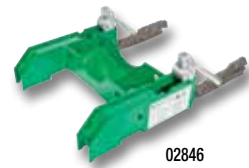
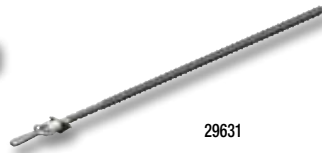

INTERNATIONAL

Tel: +1.815.397.7070
Fax: +1.815.397.9247

CANADA

Tel: 800.435.0786
Fax: 800.524.2853

USA

Tel: 800.435.0786
Fax: 800.451.2632

Package Components

			Super Tugger - 6,500 lb			
			110 VAC			220 VAC
Cat. No.	UPC No.	Description	6001	6004	6005	6001-22
6001	29627	Cable Puller w/Force Gauge 120 VAC, 60 Hz	✓	✓	✓	
6001-22	31466	Cable Puller w/Force Gauge 220 VAC, 50 Hz				✓
UT4	21552	4,000 lb. Cable Puller, 120 VAC, 60 Hz				
6037	35605	Floor Mount		✓	✓	
29631	29631	Vise Chains	✓	✓	✓	✓
11230	11230	Wheeled Carriage		✓	✓	
11145	11145	Boom Mount		✓	✓	
00791	00791	4' (1.2 m) Boom Tube		✓	✓	
00864	00864	Nose Unit		✓	✓	
00863	00863	Elbow Unit			✓	
00835	00835	3' (.9 m) Boom Tube			✓	
03661	03661	2" Screw-On Coupling				
00781	00781	2-1/2" Screw-On Coupling		✓	✓	
00782	00782	3" Screw-On Coupling		✓	✓	
00783	00783	3-1/2" Screw-On Coupling		✓	✓	
00784	00784	4" Screw-On Coupling		✓	✓	
00799	00799	Adapter for Screw-On Coupling		✓	✓	
00804	00804	2-1/2" Slip-In Coupling		✓	✓	
00811	00811	3" Slip-In Coupling		✓	✓	
00815	00815	3-1/2" Slip-In Coupling		✓	✓	
00820	00820	4" Slip-In Coupling		✓	✓	
11152	11152	Storage Trays (2)		✓	✓	
651	15325	12" Hook Sheave				

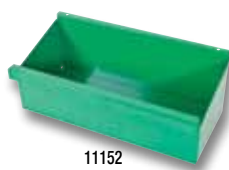

Ultra Tugger® 8 (UT8) Cable Puller: 8000 lb. (35.8kN) rated



6805A

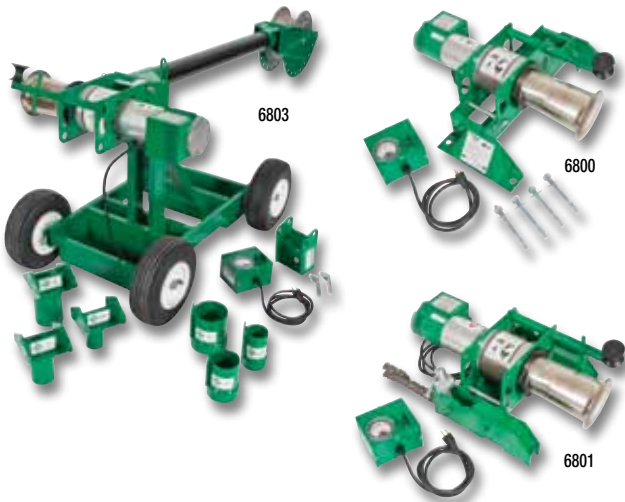

6803

6800

6801

- 8,000 (35.8 kN) lbs. pulling force.
- Pulling speed ranges from 9 fpm at 2,000 lbs. to 6 fpm at 8,000 lbs.
- Mobile Versi-Boom™ system provides fast set-up with no anchors to set or chains to mount.
- Boom uses 3" rigid steel conduit for easy length adjustment to pull 10 to 20 feet (3 to 6 m) of cable out of the box fast and easy.
- Direct gear drive
- Easy to move around jobsite with mobile carriage.
- Patented

CAT. NO.	UPC NO.	DESCRIPTION
6800	00985	Ultra Tugger 8 Cable Puller with Standard Force Gauge, and Floor Mount
6800-22	03196	Same as 6800, except 220 VAC 50 Hz
6801	00986	Ultra Tugger 8 Cable Puller with Standard Force Gauge, and Conduit Chain Mount
6803	12824	Ultra Tugger 8 Cable Puller Basic Package. Includes standard force gauge, wheeled carriage, 4 ft. (1.2 m) boom, boom mount and nose unit, 2-1/2", 3" and 4" slip-in couplings, 2-1/2", 3" and 4" screw-on couplings. Rope and storage box are optional.
6803B	12133	Same as 6803 plus 3048 Storage Box and 603 Casters
6805A	02565	Ultra Tugger 8 Cable Puller Deluxe Package. Same as 6503 plus 3-ft. (.9 m) boom, elbow unit and floor mount. Rope and storage box are optional.
6805B	12131	Same as 6805A plus 3048 Storage Box and 603 Casters
6805A-22	03201	Same as 6805A, except 220 VAC 50 Hz
6805B-22	12132	Same as 6805A-22 plus 3048 Storage Box and 603 Casters
00967	00967	A Deluxe Force Gauge (see page 158)
445	24821	A Foot Switch (see page 159)
00867	00867	A "T" Stand
00815	00815	A 3-1/2" Slip-in Coupling
00783	00783	A 3-1/2" Screw-on Coupling
654	34362	A Rope Stand
34136	34136	A Pull Rope 7/8" x 300' (22.2 mm x 91 m)
34137	34137	A Pull Rope 7/8" x 600' (22.2 mm x 182 m)
34138	34138	A Pull Rope 7/8" x 1,200' (22.2 mm x 365 m)

SPECIFICATIONS

Pulling Force	Maximum: 8,000 lbs. (35.8 kN) Continuous: 6,500 lbs. (28.9 kN)
Dimensions	Length: 11.5" (292 mm) Width: 26" (660 mm)
Height	120V models: 6.75" (172 mm) 220V models: 10.0" (254 mm)
Weight	86 lbs. (39 kg) (08000 only)
Pulling Speed – Feet (Meters) Per Minute	No Load: 9 fpm (2.7 mpm) At 2000 lbs. (0.9 kN): 8 fpm (2.4 mpm) At 4000 lbs. (1.8 kN): 7.5 fpm (2.3 mpm) At 6000 lbs. (2.7 kN): 7 fpm (2.1 mpm) At 8000 lbs. (3.6 kN): 6 fpm (1.8 mpm)
Drive Motor	1-1/2 HP (1.1 kW)
Power	8000, 6800, 6801, 6803, 6803B, 6805A, 6805B = 120 VAC 60Hz 20A
Requirements	UT8-22, 6800-22, 6805A-22, 6805B-22 = 220 VAC 50Hz
Required Rope	7/8" diameter (22.2 mm); Double-Braided Polyester Composite – Rated at 32,000 lbs. (142 kN) minimum breaking strength

NOTE: Rope is a very critical link in the cable pulling system. See page 166 for proper pulling rope selection.

*See page 150 for UT8 component list

Ultra Tugger® 5 (UT5) Cable Puller: 5,000 lb. (22.2kN) Rated



6505



6503

6501

- 5,000 lbs. (22.3 kN) pulling force, enough power to pull most 500 kcmil (240 mm²) jobs of 500 feet (152 m) or less.
- Pull speed range of 9 to 14 fpm (2.7 to 4.3 mpm) will complete most 500 ft. (152 m) pulls in 1 hour or less.
- Mobile Versi-Boom™ system provides fast setup with no anchors to set or chains to mount.
- Boom uses 3" rigid steel conduit for easy length adjustment to pull 10 to 20 feet (3 to 6 m) of cable out of the box fast and easy.
- Use 6501 Ultra Tugger 5,000 lb. (22.3 kN) capacity cable puller power unit with current 6805A Ultra Tugger wheeled carriage and boom to pull cable faster.
- Patented.

CAT. NO.	UPC NO.	DESCRIPTION
Ⓢ 6500	12822	Ultra Tugger® 5 Cable Puller Power Unit only with standard force gauge and floor mount
Ⓢ 6501	11221	Ultra Tugger® 5 Cable Puller Power Unit with standard force gauge and chain mount and vise chains
Ⓒ 6501-22	19232	Same as 6505, except 220 VAC 50 Hz
Ⓢ 6503	11222	Ultra Tugger® 5 Cable Puller Basic Package. Includes standard force gauge, wheeled carriage, 4 ft. (1.2 m) boom, boom mount and nose unit, 2-1/2", 3" and 4" slip-in couplings, 2-1/2", 3" and 4" screw-on couplings. Rope and storage box are optional.
Ⓢ 6505	11223	Ultra Tugger® 5 Cable Puller Deluxe Package. Same as 6503 plus 3-ft. (.9 m) boom, elbow unit and floor mount. Rope and storage box are optional.
Ⓒ 6505-22	32743	Same as 6505, except 220 VAC 50 Hz
00967	00967	A Deluxe Force Gauge (See page 158)
445	24821	A Foot Switch (See page 159)
00867	00867	A "T" Stand
00815	00815	A 3-1/2" Slip-in Coupling
00783	00783	A 3-1/2" Screw-on Coupling
654	34362	A Rope Stand
3048	23362	A Storage Box
603	23405	A Casters – 2 Rigid, 2 Swivel
35098	35098	A Pull Rope, 3/4" x 300 ft. (19.1 mm x 91 m) Double-Braided Composite
35100	35100	A Pull Rope, 3/4" x 600' (19.1 mm x 182 m)
35101	35101	A Pull Rope, 3/4" x 1,200' (19.1 mm x 365 m)

SPECIFICATIONS

Pulling Force	Maximum: 5,000 lbs. (22.2 kN) Continuous: 4,000 lbs. (17.8 kN)
Dimensions	Length: 11.5" (292 mm) Width: 26" (660 mm) Height: 6.75" (172 mm)
Height	120V models: 6.75" (172 mm) 220V models: 10.0" (254 mm)
Weight	84 lbs. (38 kg) (15000 only)
Pulling Speed – Feet (Meters) Per Minute	No Load: 14.5 fpm (4.4 mpm) At 4000 lbs. (1.8 kN): 11 fpm (3.4 mpm) At 5000 lbs. (2.3 kN): 9.5 fpm (2.9 mpm)
Drive Motor	1-1/2 HP (1.1 kW)
Power	15000, 6501, 6503, 6505 – 120 VAC 60Hz 20A
Requirements	UT5-22, 6505-22 – 220 VAC 50Hz
Required Rope	3/4" (19.1 mm) Double-Braided Polyester Composite - Rated at 20,000 lb. (88.8 kN) minimum breaking strength

Rope is a very critical link in the cable pulling system. See page 166 for proper pulling rope selection.

*See page 150 for UT5 component list

N = NEW PRODUCT **R** = REPLACEMENT PART **A** = ACCESSORY

Cable Pulling

USA

Tel: 800.435.0786
Fax: 800.451.2632

CANADA

Tel: 800.435.0786
Fax: 800.524.2853

INTERNATIONAL

Tel: +1.815.397.7070
Fax: +1.815.397.9247



Super Tugger® Cable Puller: 6500 lb. (28.9 kN) rated



6005



- Pull up to 6,500 lbs. (28.9 kN) with less than 27 lbs. (120 N) of operator effort.
- Unique floor mounting attachment for quick, reliable setup.
- Leaf-type mounting chains won't twist when tightening.
- Heat-treated steel serrated gripper feet for secure mounting to conduit.
- Force Gauge included to constantly monitor the pull.
- Right-angle sheave allows the operator to stand out of the direct line of force.
- Audio alarm high force warning and circuit breaker shut off at maximum force for added safety.
- Tapered capstan and patented rope guidance system for better control of the rope when feeding onto the capstan.
- Patented.

CAT. NO. UPC NO. DESCRIPTION



6001 29627 Super Tugger Cable Puller Power Unit, Includes force gauge and vise chains



6001-22 31466 Same as 6001 except 220 VAC 50 HZ



6004 56358 Super Tugger Complete Puller Package, Includes 6001 Super Tugger, Floor Mount, Mobile Carriage, Boom Mount, 4' Boom Tube, Nose Unit, 2 1/2", 3", 3 1/2", 4" Slip-in and Screw-On Couplings and Storage Trays



6005 56359 Super Tugger Complete Puller Package, Includes 6001 Super Tugger, Floor Mount, Mobile Carriage, Boom Mount, 4' Boom Tube, Nose Unit, 3' Boom Tube, Elbow Unit, 2 1/2", 3", 3 1/2", 4" Slip-in and Screw-On Couplings and Storage Trays

35098 35098 **A** Double-Braided Composite Rope 3/4" × 300' (19.1 mm × 91 m)

35100 35100 **A** Double-Braided Composite Rope 3/4" × 600' (19.1 mm × 182 m)

35101 35101 **A** Double-Braided Composite Rope 3/4" × 1,200' (19.1 mm × 365 m)

445 24821 **A** Foot Switch (See page 159)

3048 23362 **A** Storage Box (See page 410)

SPECIFICATIONS

Pulling Force Maximum: 6,500 lbs. (28.9 kN)
Continuous: 4,500 lbs. (20 kN)

Dimensions Length: 20-3/4" (527 mm)
Width: 22-1/2" (572 mm)
Height: 12" (305 mm)

Weight 6001, 6001-22: 108 lbs. (49 kg)
6003: 454 lbs. (206 kg)
6000, 6000-22: 550 lbs. (250 kg)
6006, 6006-22: 612 lbs. (278 kg)

Pulling Speed – Feet (Meters) Per Minute

No Load: 16.5 (5)
At 2000 lbs.: (8.8 kN) – 11 (3.4)
At 4000 lbs.: (17.9 kN) – 7.5 (2.3)
At 6000 lbs.: (26.7 kN) – 6 (1.8)

Drive Motor 1-1/2 HP (1.1 kW)

Power Requirements 6001, 6004, 6005 – 120 VAC 16Hz 20A
6001-22 – 220 VAC 50Hz

Required Rope 3/4" (19.1 mm) Double-Braided Composite
– Rated at 26,000 lbs. (115.6 kN)

6004



6001



Cable Pulling

INTERNATIONAL

Tel: +1.815.397.7070
Fax: +1.815.397.9247

CANADA

Tel: 800.435.0786
Fax: 800.524.2853

USA

Tel: 800.435.0786
Fax: 800.451.2632

NOTE: Rope is a very critical link in the cable pulling system. See page 166 for proper pulling rope selection.

Ultra Tugger® 4 (UT4) Cable Puller: 4,000 lb. (22.2kN) Rated

NEW



UT4



Connect for an upward pull



Connect for a downward pull



Connect at floor height



Optional 12' boom extension for high pulls



Optional floor mount

- Two pulling speeds to match the job.
- Quick Latch system attaches to the outside of threaded and unthreaded conduit without the need for adapters.
- Quick Set-Ups & Tear Downs- roll it to the job, adjust the boom and nose & attach it to the conduit.
- Boom extends to 8'. A 12' boom extension accessory is available.
- Integral foot operated on/off switch.
- Nose can be turned for up, down & side pulls.
- Rolls easily between job locations.
- Available floor mount accessory for use in tight spaces.
- Patented.

CAT. NO. UPC NO. DESCRIPTION

CAT. NO.	UPC NO.	DESCRIPTION
UT4	21552	4,000 lb. Cable Puller
10014	10014	A Floor Mount for UT4 Cable Puller
10015	10015	A 12' Long Extension Boom for UT4 Cable Puller
35283	35283	A Double-Braided Composite Rope 9/16" x 300' (14.3 mm x 91 m)
35284	35284	A Double-Braided Composite Rope 9/16" x 600' (14.3 x 182 m)
35285	35285	A Double-Braided Composite Rope 9/16" x 1,200 (14.3 mm x 365 m)
3048	23362	A Storage Box
2142	31651	A Storage Box (requires boom to be removed from puller)

SPECIFICATIONS

Maximum Pulling Force	High Speed 2,000 lbs. (909 kg) Low Speed 4,000 lbs. (1,818 kg)
Continuous Pulling Force:	Low Speed 3,000 lbs. (1,364 kg)
High Pulling Speeds:	No Load 26 fpm (8 mpm) 2,000 lbs. (909 kg) 20 fpm (6 mpm)
Low Pulling Speeds:	No Load 13 fpm (4 mpm) 2,000 lbs. (909 kg) 10 fpm (3 mpm)
*Pulling Rope:	9/16" diameter double braided composite (16,000 lbs. minimum breaking strength)
Conduit Size:	2" to 4"
Weight:	175 lbs. (80kg)
Drive Motor:	1-1/4 hp, 120 VAC, 60 Hz
Electrical Plug:	120 V, 15 Amp
Force Gauge:	Standard
Foot Switch:	Standard
Standard Boom Extension:	8' (2.4 m) maximum
Optional Long Boom Extension:	12' (3.6 m) maximum
Pulling Capability:	3 x 750 kmil cable 600' with 2 x 90° bends 4 x 350 kmil cable 400' with 4 x 90° bends 3 x 500 kmil cable 400' with 3 x 90° bends

* Greenlee recommends that only low stretch double braided composite rope be used with the UT4. High stretch ropes can release large amounts of energy should they break during use.

Cable Pulling

USA

Tel: 800.435.0786
Fax: 800.451.2632

CANADA

Tel: 800.435.0786
Fax: 800.524.2853

INTERNATIONAL

Tel: +1.815.397.7070
Fax: +1.815.397.9247



Ultra Tugger[®] 2 Cable Puller: 2000 lb. (8.8 kN) Rated

- Quick Latch System attaches to all conduit sizes with no loose parts.
- Adjustable elbow and extendable boom adjust easily to fit your job needs.
- Right Angle Sheave keeps operator out of direct line with the pulling rope.
- Dual Diameter capstan provides 2 pulling speeds.
- Cross Tube provides a solid base for setup and during pull.
- Integral Motor designed specifically for cable pulling applications.
- Circuit Breaker stops the puller motor if it becomes overloaded.
- Wheels provide easy movement around jobsite.



CAT. NO. UPC NO. DESCRIPTION

CAT. NO.	UPC NO.	DESCRIPTION
UT2	02010	2,000 LB. Cable Puller Unit
56362	56362	A Trailer hitch adapter (fits 2" receiver)
2448	23273	A Storage Box
455	23774	A 1/2" x 300' (12.7 mm x 91 m) Double Braided Rope
456	23777	A 1/2" x 600' (12.7 mm x 182 m) Double Braided Rope
445	24821	A Foot Switch (See page 159)

SPECIFICATIONS

Pulling Force High Speed Capstan 1,000 lb. (455 kg) continuous
Low Speed Capstan 2,000 lb. (909 kg) continuous

Drive Motor 120 VAC, 50/60 Hz, 12 Amps

Weight 67 lbs.

Pulling Speeds **High Speed Capstan**
No Load: 73 fpm (22 mpm)
500 lb. Load (227 kg) 36 fpm (11 mpm)
1,000 lb. Load (455 kg) 22 fpm (7 mpm)

Low Speed Capstan
No Load: 41 fpm (12 mpm)
1,000 lb. Load (455 kg) 36 fpm (11 mpm)
2,000 lb. Load (909 kg) 22 fpm (7 mpm)

Pulling Rope 1/2" polyester (10,000 lb. minimum breaking strength)
*Greenlee recommends that only low stretch polyester rope be used with the UT2. High stretch ropes can release large amounts of energy should they break during use.

Conduit Size 1" or larger

Pulling Capabilities 3 x 500 kcmil cable 500' with 2 x 90° bends
3 x 500 kcmil cable 250' with 4 x 90° bends
8 x 4/0 AWG cable 300' with 3 x 90° bends



UP PULL



DOWN PULL



SIDE PULL

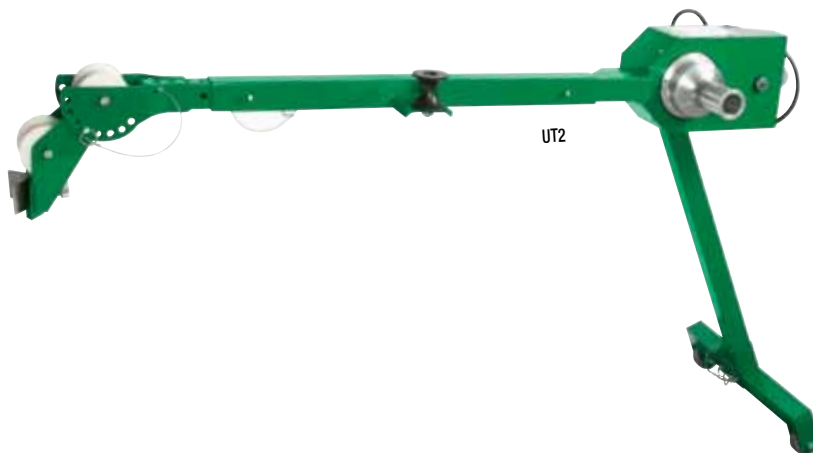

Cable Pulling

INTERNATIONAL

Tel: +1.815.397.7070
Fax: +1.815.397.9247

CANADA

Tel: 800.435.0786
Fax: 800.524.2853

USA

Tel: 800.435.0786
Fax: 800.451.2632

NOTE: Rope is a very critical link in the cable pulling system. See page 166 for proper pulling rope selection.

Hand Crank Wire Puller



- Pull up to 1500 lbs. (6.7 kN) with only 30 lbs. (133 N) of crank handle force.
- Two-speed ratchet winder for fast, efficient operation.
- Has 200' (61 m) of steel aircraft cable.
- Completely self-contained and ready to operate.

CAT. NO.	UPC NO.	DESCRIPTION
766	18202	Hand Crank Wire Puller
50954	50954	200' (61 m) spool of steel cable
13955	14568	Shear Pin
28280	28280	Crank Handle Assembly

SPECIFICATIONS

Pulling Force	Maximum - 1500 lbs. (6.6 kN)
Size	200' (61 m) pulling cable length
Weight	38 lbs. (17.2 kg)
Power	Manual - 2-Speed Hand Crank
Dimensions	Length - 52" (1.32 m) Width - 18" (457 mm) Height - 10" (254 mm)

11147 Ultra Tugger® 640/6001 Adapter Package

CAT. NO.	UPC NO.	DESCRIPTION
11147	11147	Ultra Tugger 640/6001 Adapter Package Includes wheeled carriage, 4 ft. (1.2 m) boom, boom adapter, nose unit, 2-1/2", 3" and 4" slip-in couplings and 2", 3" and 4" screw-on couplings
00863	00863	A Elbow Unit
00835	00835	A 3 ft. (.9 m) Boom
00815	00815	A Slip-in Coupling, 3-1/2"
00827	00827	A Slip-in Coupling, 5"
00781	00781	A Screw-on Coupling, 2-1/2"
00783	00783	A Screw-on Coupling, 3-1/2"
3048	23362	A Storage Box

- Adapt Greenlee 640 Tugger and 6001 Super Tugger to Ultra Tugger Wheeled Carriage and Boom for faster and easier cable puller setups.
- Wheeled carriage and boom provides fast setup with no anchors to set or chains to mount.
- Boom uses 3" rigid steel conduit for easy length adjustment to pull 10 feet (3m) of cable out of the box fast and easy.
- Optional Elbow Unit and Boom available to reach into manholes or pull up to 20 feet (6 m) of cable out of the box.
- Patent pending.

SPECIFICATIONS

Weight	198 lbs. (90 kg)
Length	91-1/2" (232 cm)
Width	27" (69 cm)
Height	38-1/2" (98 cm)
Use With	Greenlee 640 and 6001 Cable Pullers
Load Rating	6500 lbs. (28.9 kN)





TUGGER ACCESSORIES

Speed Booster (for UT8 and UT5)



- The Speed Booster increases the speed of the Tugger to pull approximately twice as fast as normal.
- For use with the Greenlee Ultra Tugger 5 and Ultra Tugger 8 cable pullers only.
- Increases productivity on lower force runs and during the initial phase of a high force pull.
- Automatically switches to low speed at 2,500 lbs. (11.1 kN) to protect the puller motor.
- Ultra Tugger adapter cord and plug included.

CAT. NO.	UPC NO.	DESCRIPTION
----------	---------	-------------

03561	03561	Ultra Tugger Speed Booster
04884	04884	Ultra Tugger Cord and Plug Kit

SPECIFICATIONS

Capacity	0 to 2,500 lbs. (11.1 kN) pulling force in high speed mode
Dimensions	Height: 9.5" (241.3 mm); Width 13" (330.2 mm); Depth: 15.5" (393.7 mm)
Weight	46 lbs. (20.9 kg)
Pulling Speed, No Load	28 fpm (8.5 mpm);
Ultra Tugger 5	At 1200 lbs. (5.3 kN) - 25 fpm (7.6 mpm)
Pulling Speed, No Load	18 fpm (5.5 mpm);
Ultra Tugger 8	At 2000 lbs. (8.8 kN) - 16 fpm (4.9 mpm)
Power	115 VAC, 15A Input; 115/230 VAC, 15/6A Output

Deluxe Force Gauge



- Measures tension on the rope, to an accuracy of $\pm 5\%$.
- Accuracy is not affected by initial rope size, or the change in rope size as it is loaded.
- 0-10 VDC Analog output to optional strip chart recorder for permanent record of pulling force.
- Switchable 120VAC receptacle for chart recorder.
- Use with pulling rope up to 7/8" diameter (22.2 mm) maximum. Also use with Kevlar[®] tape.

CAT. NO.	UPC NO.	DESCRIPTION
----------	---------	-------------

00967	00967	Deluxe Force Gauge
33901	33901	Strip Chart Recorder
22410	22410	Fan Fold Chart Paper- 15 pack
22451	22451	Recorder Pens- 5 pack

SPECIFICATIONS

Deluxe Force Gauge	Accuracy $\pm 5\%$
---------------------------	--------------------

- Use with any puller that uses Versi-Boom system.
Including : 6805A, 6805A-22, 6803, 6505, 6505-22, 6503, 6005, 6004, 645 and 643



Cable Pull Force Estimator

NEW



- Calculates estimated cable pulling force requirements based on user inputs
- Simple to follow instructions included on the calculator
- Consists of an Excel based calculator that can be used either from the supplied CD or downloaded.
- Works with Windows 7, Vista, XP and Mac OS.

CAT. NO.	UPC NO.	DESCRIPTION
PF8	20956	Cable Pull Force Estimator* (CD-ROM)

*Microsoft® Excel Required

Foot Switch for Cable Pullers



- Use with UT2, 640, 6001, 6500 or 6800 cable pullers to add foot control.
- Foot pressure required to operate.

CAT. NO.	UPC NO.	DESCRIPTION
445	24821	Foot Switch

SPECIFICATIONS

Power Source	120 VAC
Weight	9.5 lbs. (4.3 kg)

Slip-in Couplings



- Use to attach the Versi-Boom™ to the conduit.
- Couplings slip into the conduit and pin to the Versi-Boom.
- For use with the Versi-Boom system only.

CAT. NO.	UPC NO.	SIZE	WEIGHT
00804	00804	2.5"	6 lbs (2.7 kg)
00811	00811	3"	7 lbs (3.2 kg)
00815	00815	3.5"	9 lbs (4.1 kg)
00820	00820	4"	11 lbs (5 kg)
00827	00827	5"	13 lbs (5.8 kg)

Screw-on Couplings



- Use to attach the Versi-Boom™ to the conduit when pulling from overhead.
- The coupling and adapter threads onto the conduit and pins to the Versi-Boom.
- The screw-on coupling and adapter must be used together. One adapter fits all of the screw-on couplings.

CAT. NO.	UPC NO.	DESCRIPTION	WEIGHT
00799	00799	Adapter	7.4 lbs (3.4 kg)
00877	00877	Screw Assembly	0.5 lbs (0.2 kg)

CAT. NO.	UPC NO.	SIZE	WEIGHT
00868	00868	2-1/2", 3", 3-1/2", and 4"	22 lbs (10.0 kg)
03661	03661	2"	2.1 lbs (1.0 kg)
00781	00781	2-1/2"	3.1 lbs (1.4 kg)
00782	00782	3"	4.4 lbs (2.2 kg)
00783	00783	3-1/2"	5.6 lbs (2.5 kg)
00784	00784	4"	5.7 lbs (2.6 kg)



Hook Sheaves - 8,000lb Capacity



- For use with UT8, UT5, 6001, UT4 and UT2 cable pullers.
- Strong, welded steel frames.
- Forged steel closure type hooks with 1" (25.4 mm) opening.
- All three sheaves are aluminum alloy with self-lubricating bearings.

SHEAVE DIAMETER	8012 12" (304.8 mm)		8018 18" (457.2 mm)		8024 24" (609.6 mm)	
	CAT. NO.	UPC NO.	CAT. NO.	UPC NO.	CAT. NO.	UPC NO.
Roll Pin	50700	50700	50700	50700	50700	50700
Sheave Pin	00838	00838	00846	00846	00850	00850
Sheave Pin Clip	50302	50302	50302	50302	50302	50302
Sheave Unit	00843	00843	00844	00844	00845	00845
Yoke Frame	00854	00854	00855	00855	00856	00856

SPECIFICATIONS

CAT. NO.	UPC NO.	OUTSIDE DIAMETER	INSIDE RADIUS	WIDTH	WEIGHT	MAXIMUM RATED CAPACITY
8012	00872	12" (304.8 mm)	3-7/8" (98.4 mm)	5" (127 mm)	28 lbs (12.7 kg)	8,000 lbs. (35.8 kN)
8018	00873	18" (457.2 mm)	7" (177.8 mm)	6" (152.4 mm)	44 lbs (19.9 kg)	8,000 lbs. (35.8 kN)
8024	00874	24" (609.6 mm)	9-7/8" (250.8 mm)	6-1/2" (165.1 mm)	67 lbs (30.3 kg)	8,000 lbs. (35.8 kN)

Hook-Type Sheaves - 4,000lb Capacity



- Strong, welded steel frames.
- Forged steel closure-type hooks with 1" (25.4 mm) opening.
- 5" (127 mm) wide aluminum alloy sheaves with self-lubricating bearings.
- Select a sheave with a maximum rated capacity that meets or exceeds the cable puller's maximum pulling force.

CAT. NO.	UPC NO.	DESCRIPTION
650	15324	6" (152.4 mm) dia. Hook Sheave with 1-1/2" (38.1 mm) minimum radius
651	15325	12" (304.8 mm) dia. Hook Sheave with 3-5/16" (84.1 mm) minimum radius
652	15326	18" (457.2 mm) dia. Hook Sheave with 7" (177.8 mm) minimum radius
653	15327	24" (609.6 mm) dia. Hook Sheave with 9-13/16" (249.2 mm) minimum radius

SPECIFICATIONS

Maximum Rated Capacity	4,000 lbs. (17.8 kN)
Weight	650 - 8.8 lbs. (4 kg) 651 - 15 lbs. (6.8 kg) 652 - 25 lbs. (11.3 kg) 653 - 35 lbs. (15.9 kg)

SHEAVE DIAMETER	650 6" (152.4 mm)		651 12" (304.8 mm)		652 18" (457.2 mm)		653 24" (609.6 mm)	
	CAT. NO.	UPC NO.	CAT. NO.	UPC NO.	CAT. NO.	UPC NO.	CAT. NO.	UPC NO.
Sheave Pin	16797	16797	16797	16797	16797	16797	16797	16797
Sheave Pin Clip (2)	50302	50302	50302	50302	50302	50302	50302	50302
Sheave	15362	15362	15358	15358	15363	15363	15364	15364
Sheave Bushing (2)	16798	16798	16798	16798	16798	16798	16798	16798
Yoke Frame	16799	16799	16800	16800	16801	16801	16802	16802

Right-Angle Twin Yoke Sheave - 4,000lb Capacity



- 9-13/16" (249 mm) minimum radius.
- Strong welded steel yokes.
- Forged steel closure type hook with 1" (25.4 mm) opening.
- 5" (127 mm) wide aluminum alloy sheave with self-lubricating bearings.
- Yokes rotate independently to fit various setups.
- Use with any cable puller whose maximum pulling force is 4,000 lbs. (17.8 kN) or less.

CAT. NO.	UPC NO.	DESCRIPTION
639	17265	Right Angle Twin Yoke Sheave with 9-13/16" (249 mm) minimum radius

SHEAVE DESCRIPTION	639 CAT. NO.	UPC NO.	QUANTITY
Sheave Pin	17266	17266	1
Sheave Pin Clip	50302	50302	2
Sheave	15364	15364	1
Sheave Bushing	16798	16798	2
Yoke Frame	17299	17299	2

NOTE: Rope is a very critical link in the cable pulling system. See page 166 for proper pulling rope selection.

Conveyor Sheaves - 4,000lb Capacity

NEW



- Welded steel frame with a series of sheaves to form a large radius.
- Yokes with cast steel closure-type hooks with a 1" (25.4 mm) opening.
- 5" (127 mm) wide aluminum alloy sheaves.
- Use with any cable puller whose maximum pulling force is 4,000 lbs. (17.8 kN) or less.

CAT. NO.	UPC NO.	DESCRIPTION
4024	26368	24" (609.6 mm) Conveyor Sheave with 6 sheave wheels
4036	26369	36" (914.4 mm) Conveyor Sheave with 8 sheave wheels
4048	26370	48" (1219 mm) Conveyor Sheave with 10 sheave wheels
19185	19185	R Yoke frame
15362	15362	R Sheave w/bearings
19186	19186	R Sheave Pin
50302	50302	R Sheave Pin Clip (2)
31573	31573	R Sheave Pin

SPECIFICATIONS

Maximum Pulling Force	4,000 lbs. (17.8 kN)
Weight	4024 - 54 lbs. (24.5 kg)
	4036 - 60 lbs. (27 kg)
	4048 - 83 lbs. (38 kg)

Triple Sheave Cable Guide - 6,500lb Capacity



- Adjustable center sheave for 19-1/2" (495 mm) or 36" (914 mm) radius.
- Forged steel closure type hook with 1-1/2" (38.1 mm) opening.
- Aluminum frames for light weight.
- Steel yoke is pinned for easy removal.
- 21-7/8" (555 mm) high, 24" (610 mm) long, 7-3/8" (187 mm) wide with 5" (127 mm) wide sheaves.
- Use with any cable puller whose maximum pulling force is 6,500 lbs. (28.9 kN) or less.

SHEAVE DESCRIPTION	6036 CAT. NO.	UPC NO.	QUANTITY
Sheave Axle	31573	31573	3
Sheave Bolt Washer	51434	51434	6
Sheave Pin	29600	29600	1
Sheave Pin Clip	50302	50302	2
Sheave Bushing	16798	16798	6
Sheave	15362	15362	3

Sheave Bolt is a 3/8"-24 x 3/4" hex head socket head cap screw (grade 5) and is available at most hardware stores.

CAT. NO.	UPC NO.	DESCRIPTION
6036	31569	Triple Sheave Cable Guide

SPECIFICATIONS

Maximum Rated Capacity	6,500 lbs. (28.9 kN)
Weight	28 lbs. (12.7 kg)



Feeding Sheaves



- Yoke frame slides into the end of conduit and holds sheave, allowing the cable being fed into the conduit to smoothly roll over the sheave.
- 5" (127 mm) wide aluminum alloy sheave with self-lubricating bearings.
- Split tube for easy removal after cable is installed.
- See the Capacity Table (below).

SPECIFICATIONS

Rated Capacity See Capacity Table Below for details.

Weight	Width of Shaft Opening
441-2 – 9 lbs. (4.5 kg)	441-2 – 1.24"
441-2-1/2 – 11 lbs. (5 kg)	441-2-1/2 – 1.37"
441-3 – 14 lbs. (6.4 kg)	441-3 – 1.79"
441-3-1/2 – 17 lbs. (7.7 kg)	441-3-1/2 – 1.75"
441-4 – 19 lbs. (8.6 kg)	441-4 – 1.99"
441-5 – 26 lbs. (11.8 kg)	441-5 – 2.23"
441-6 – 28 lbs. (12.7 kg)	441-6 – 2.75"



SHEAVE CONDUIT SIZE DESCRIPTION	441-2 2" CONDUIT		441-2-1/2 2-1/2" CONDUIT		441-3 3" CONDUIT		441-3-1/2 3-1/2" CONDUIT		441-4 4" CONDUIT		441-5 5" CONDUIT	
	CAT. NO.	UPC NO.	CAT. NO.	UPC NO.	CAT. NO.	UPC NO.	CAT. NO.	UPC NO.	CAT. NO.	UPC NO.	CAT. NO.	UPC NO.
Sheave Pin	25160	25160	25160	25160	25160	25160	25160	25160	25160	25160	25160	25160
Sheave Pin Clip (2)	50302	50302	50302	50302	50302	50302	50302	50302	50302	50302	50302	50302
Sheave	15362	15362	15362	15362	15362	15362	15362	15362	15362	15362	15362	15362

CAPACITY TABLE

ANGLE OF PULL	ANGLE					
	441-2	441-2-1/2	441-3	441-3-1/2	441-4	441-5
15°	1750 lbs.	1900 lbs.	6050 lbs.	6500 lbs.	6500 lbs.	6500 lbs.
	7.7 kN	8.4 kN	26.9 kN	28.9 kN	28.9 kN	28.9 kN
30°	900 lbs.	1000 lbs.	3150 lbs.	5050 lbs.	6500 lbs.	6500 lbs.
	4.0 kN	4.4 kN	14.0 kN	22.4 kN	28.9 kN	28.9 kN
45°	650 lbs.	700 lbs.	2200 lbs.	3550 lbs.	5200 lbs.	6500 lbs.
	2.8 kN	3.1 kN	9.7 kN	15.7 kN	23.1 kN	28.9 kN
60°	500 lbs.	550 lbs.	1800 lbs.	2900 lbs.	4200 lbs.	6000 lbs.
	2.2 kN	2.4 kN	8.0 kN	12.8 kN	18.6 kN	26.6 kN
75°	450 lbs.	500 lbs.	1600 lbs.	2600 lbs.	3650 lbs.	5500 lbs.
	2.0 kN	2.2 kN	7.1 kN	11.5 kN	16.2 kN	24.4 kN
90°	450 lbs.	500 lbs.	1550 lbs.	2500 lbs.	3500 lbs.	5250 lbs.
	2.0 kN	2.2 kN	6.8 kN	11.1 kN	15.5 kN	23.3 kN

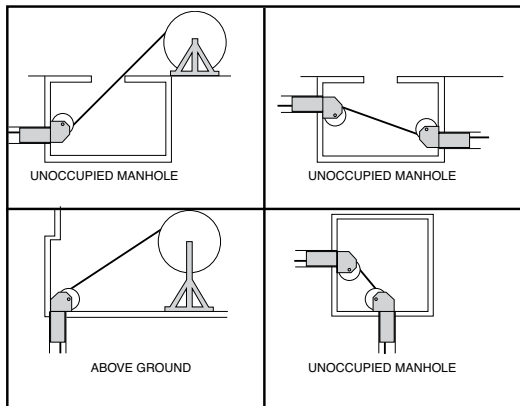

Manhole Sheaves for UT2®, Tugger® and Super Tugger®



- High-strength aluminum alloy frame for easy setup.
- Adjustable, a full range of sheave pin positions over the frame length to accommodate most manhole setups.
- 18" (457 mm) diameter aluminum alloy sheaves with 7" (178 mm) minimum radius and 5" (127 mm) width.
- Self-lubricating bearings for easier cable pulling.

SPECIFICATIONS

Maximum Rated Capacity	6072 - 6,500 lbs. (28.9 kN)
Weight	6072 - 190 lbs. (86.2 kN)

CAT. NO. UPC NO. DESCRIPTION

6072	31395	12' (3.7 m) Manhole Sheave
------	-------	----------------------------

Nylon Cable Protector



- Fits in the end of conduit to shield the cable from sharp edges as it is being fed through.
- Rugged nylon resists abrasion.

CAT. NO.	UPC NO.	DESCRIPTION
488-2	32928	Nylon Cable Protector for 2" and 2-1/2" conduit
488-3	32929	Nylon Cable Protector for 3" - 6" conduit

SPECIFICATIONS

Weight	488-2 - 0.08 lbs. (36 g) 488-3 - 0.2 lbs. (90 g)
---------------	---

Cable Guide



- Position where cables are being pulled over sharp edges.

CAT. NO.	UPC NO.	DESCRIPTION
489	32930	Nylon Cable Guide

SPECIFICATIONS

Weight	489 - .5 lbs. (227 g)
Size	13" L x 3-1/4" W x 12" radius

Light Base Sheave



- Mounts directly to existing square light pole bolt patterns.
- Slotted mounting holes fit a wide range of bolt circle sizes.
- Tall enough to position sheave above most conduits.
- Rugged welded steel base structure.
- Allows user to install wires into outdoor light bases by pulling horizontally.
- Also can be used to feed wires into vertical light base conduit.

CAT. NO.	UPC NO.	DESCRIPTION
459	89800	Light Base Sheave

SPECIFICATIONS

Overall Height	14-1/2" (368 mm)
Weight	18 lbs. (8.2 kg)
Bolt Circle Capability	7.8" (198 mm) to 14.8" (376 mm) diameter
Maximum Mounting Bolt Dia.	1" (25 mm) diameter at 7.8" (198 mm) bolt circle 1-1/2" (38 mm) at 14.8" (376 mm) bolt circle
Pulling Capacity	500 lbs. (227 kg)

CR25

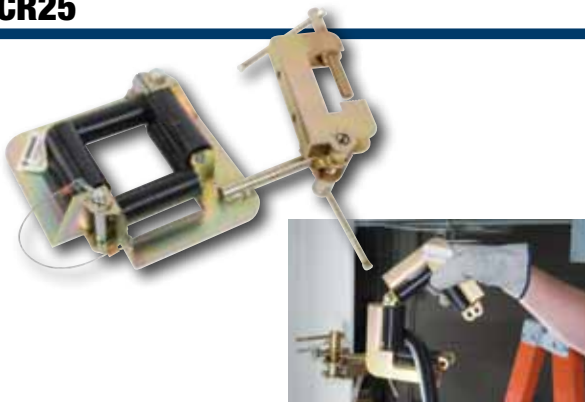

- Six nylon rollers provide smooth movement of cable and prevent cable damage.
- Pull pin makes opening and closing to insert and remove cables a simple one step operation.
- Adjustment clamp allows the CR25 to be swiveled and/or rotated into any position.
- Heavy duty 12 gauge cold rolled steel construction for durability and zinc dichromate finish prevents corrosion.
- Up to 20 network cables can be pulled at one time.
- Easily attaches to wooden framing members using a lag bolt and the hole in the mounting bracket of the CR25.
- May also be used with coax, NM, small size THHN, and similar cables.

SPECIFICATIONS

Roller Opening Size	3" (76 mm) square
Weight	2 lb. (1 kg)

SPECIFICATIONS

CAT. NO.	UPC NO.	DESCRIPTION
CR25	12211	Cable Roller Guide

NOTE: Rope is a very critical link in the cable pulling system. See page 166 for proper pulling rope selection.



CABLE TRAY ACCESSORIES

Tray-Type Sheaves

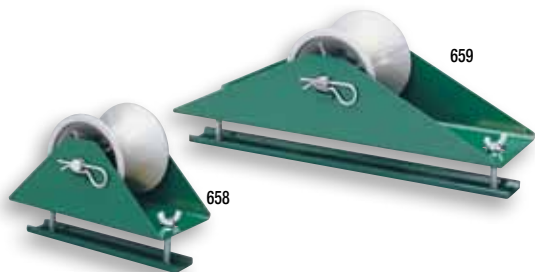

- Steel frame easily attaches to cable tray up to 2" (50.8 mm) thick.
- Helps roll and guide tray pulls.
- Make tray pulls easier.
- 5" (127 mm) wide aluminum alloy sheaves with self lubricating bearings.

CAT. NO.	UPC NO.	DESCRIPTION
658	15332	Tray-Type Sheave
659	19094	Tray-Type Sheave

SPECIFICATIONS

Size	658 – 12" (304.8 mm) long	659 – 22" (558.8 mm) long
Weight	658 – 11 lbs. (5 kg)	659 – 17 lbs. (7.7 kg)

Cable Tray Rollers

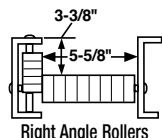
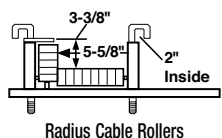
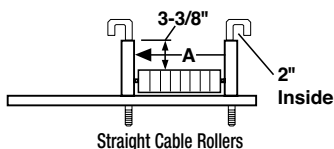

- Installed up through the bottom of the tray for easy removal after the cable is installed.
- Individual rollers keep rolling with each cable even after several cables have been installed in the tray.
- Steel ball bearing rollers for long life and less friction.
- Steel welded frame.
- Adjustment slots and universal mounting brackets.

CAT. NO.	UPC NO.	DESCRIPTION
28170	28170	J-Hook

CAT. NO.	UPC NO.	DIMENSION A
2018S	27383	6-5/16" (160.3 mm)
2024S	27384	12-1/2" (317.5 mm)
2030S	27386	18-11/16" (474.7 mm)
2036S	27387	24-7/8" (631.8 mm)

SPECIFICATIONS

Weight	2018S – 8 lbs. (3.6 kg)	2018R – 11 lbs. (5 kg)
	2024S – 10 lbs. (4.5 kg)	2024R – 12 lbs. (5.4 kg)
	2030S – 13 lbs. (5.9 kg)	2030R – 13 lbs. (5.9 kg)
	2036S – 15 lbs. (6.8 kg)	2036R – 14 lbs. (6.3 kg)
	20249R – 41 lbs. (18.6 kg)	20369R – 53 lbs. (24 kg)

CAT. NO.	UPS NO.	DESCRIPTION
STRAIGHT CABLE ROLLERS		
2018S	27383	Straight Cable Roller for 12" - 18" (304.8 - 457.2 mm) wide tray
2024S	27384	Straight Cable Roller for 20" - 24" (508 - 609.6 mm) wide tray
2030S	27386	Straight Cable Roller for 24" - 30" (609.6 - 762 mm) wide tray
2036S	27387	Straight Cable Roller for 30" - 36" (762 - 914.4 mm) wide tray
RADIUS CABLE ROLLERS		

2018R	27388	Radius Cable Roller for 12" - 18" (304.8 - 457.2 mm) wide tray
2024R	27389	Radius Cable Roller for 20" - 24" (508 - 609.6 mm) wide tray
2030R	27390	Radius Cable Roller for 24" - 30" (609.6 - 762 mm) wide tray
2036R	27391	Radius Cable Roller for 30" - 36" (762 - 914.4 mm) wide tray

RIGHT ANGLE CABLE ROLLERS		
20249R	27392	Right Angle Rollers 24" (609.6 mm) radius 90°
20369R	27393	Right Angle Rollers 36" (914.4 mm) radius 90°

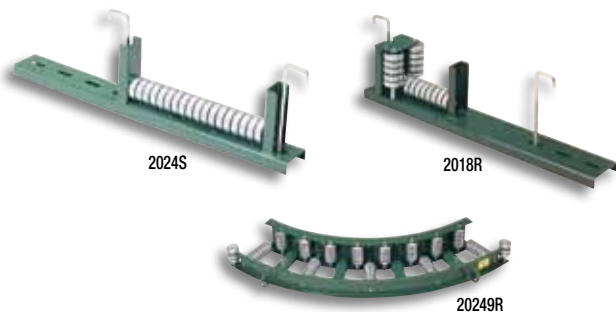

Haines Cable Tray Rollers



- Highly economical system of 1-1/2" steel conduit spindles, high-impact ABS plastic rollers and simple clips.
- Rollers snap in and out of clips fast and easy.
- Mounting clips fit onto the top of most I-Beam and C-Channel trays, so existing wire is not disturbed.
- 8" (203.2 mm) to 48" (1219.2 mm) wide rollers are available, using expandable roller halves and 3" (76.2 mm) PVC conduit.
- Use Greenlee Cable-Cream™ (see p. 172) to lube spindle and roller. This lubricant is compatible with all cable insulation types.

CAT. NO.	UPC NO.	DESCRIPTION	SIZE
31931	31931	Haines Roller	7" (177.8 mm) wide 6" (152.4 mm) dia.
31925	31925	Expandable Roller Half	Used to make 8" (203.2 mm) to 48" (1219.2 mm) wide roller
31926	31926	Coupling	3-1/2" (88.9 mm) dia. 3" (76.2 mm) long
31927	31927	Mounting Clip Steel Conduit	Use with 1-1/2" Rigid
31930	31930	Spindle (includes End Caps)	1-1/2" Rigid Conduit x 40" (1016 mm) long
31929	31929	End Cap	Fits 1-1/2" Rigid Conduit

Rope Stands



- Use to organize and rewind rope.
- Welded steel with washer and spring clip to hold rope reel on stand.

ROPE STAND	UPC NO.	ROPE DIAMETER							
		3/16"	1/4"	3/8"	1/2"	9/16"	5/8"	3/4"	7/8"
ROPE LENGTH		4.8 mm	6.4 mm	9.5 mm	12.7 mm	14.3 mm	15.9 mm	19.1 mm	22.2 mm
405 Rope Stand	21546								
250' (76 m) Rope		✓	✓						
600' (182 m) Rope		✓							
406 Rope Stand	21550								
300' (91 m) Rope				✓	✓				
600' (182 m) Rope			✓						
1,000' (305 m) Rope		✓	✓						
3,000' (914 m)									
Conduit Measuring Tape			✓	✓	✓				
Measuring Tape Cat./UPC No.			39243	39244	39245				
644 Rope Stand	15316								
300' (91 m)						✓	✓		
600' (182 m)				✓	✓	✓	✓		
1,200' (365 m)				✓					
654 Rope Stand	34362								
300' (91 m)								✓	✓
600' (182 m)								✓	✓

See page 166 for rope

SPECIFICATIONS

ROPE STAND MODEL	WEIGHT	SPINDLE DIAMETER	MAXIMUM REEL DIAMETER	MAXIMUM REEL WIDTH
405	5.2 lbs (2.4 kg)	1.50" (38 mm)	10"	6"
406	7.8 lbs (3.5 kg)	0.62" (16 mm)	13'	9"
644	11 lbs (5 kg)	1.50" (38 mm)	17"	16"
654	32.1 lbs (14.6 kg)	1.90" (48 mm)	24"	19"



Double-Braided Composite Rope for Cable Pullers



- Double-braided inner core with an extra double-braided outer jacket for added strength and less stretch; white with green tracer.
- Rot and mildew resistant.
- Factory spliced eyes at both ends.
- Lowest stretch.
- Select a rope with a maximum rated capacity that meets or exceeds the cable puller's maximum pulling force.



ROPE DIAMETER	ROPE LENGTH	CAT. NO.	UPC NO.	MAXIMUM RATED CAPACITY		AVERAGE BREAKING STRENGTH		WEIGHT		ROPE STAND	
								LBS.	kg		
FOR THE 805 PULLER											
3/8" (9.5 mm)	300'	91 m	450	23773	1200 lbs.	3.6 kN	3700 lbs.	16.4 kN	14.3	6.5	406
	600'	182 m	451	23775	1200 lbs.	3.6 kN	3700 lbs.	16.4 kN	31.0	14.3	644
	1,200'	365 m	452	23776	1200 lbs.	3.6 kN	3700 lbs.	16.4 kN	60.0	27.2	644
FOR THE UT2 PULLER											
1/2" (12.7 mm)	300'	91 m	455	23774	2,200 lbs.	8.9 kN	10,000 lbs.	44.4 kN	34	15.4	644
	600'	182 m	456	23777	2,200 lbs.	8.9 kN	10,000 lbs.	44.4 kN	75	34	644
FOR THE UT4 & 640 PULLER											
9/16" (14.3 mm)	300'	91 m	35283	35283	4,000 lbs.	17.8 kN	16,000 lbs.	71.1 kN	28	12.7	644
	600'	182 m	35284	35284	4,000 lbs.	17.8 kN	16,000 lbs.	71.1 kN	63	28.6	644
	1,200'	365 m	35285	35285	4,000 lbs.	17.8 kN	16,000 lbs.	71.1 kN	130	59	†
FOR THE 6001 & 6501 (UT5) PULLER											
3/4" (19.1 mm)	300'	91 m	35098	35098	6,500 lbs.	28.9 kN	26,000 lbs.	115.6 kN	58	26.3	644
	600'	182 m	35100	35100	6,500 lbs.	28.9 kN	26,000 lbs.	115.6 kN	113	51.3	654
	1,200'	365 m	35101	35101	6,500 lbs.	28.9 kN	26,000 lbs.	115.6 kN	230	104.3	†
FOR THE 6800 (UT8) PULLER											
7/8" (22.2 mm)	300'	91 m	34136	34136	8,000 lbs.	35.6 kN	32,000 lbs.	142.3 kN	90	40.8	654
	600'	182 m	34137	34137	8,000 lbs.	35.6 kN	32,000 lbs.	142.3 kN	178	80.7	654
	1,200'	365 m	34138	34138	8,000 lbs.	35.6 kN	32,000 lbs.	142.3 kN	359	163.3	†

† This rope does not fit on a rope stand. Use reel jacks and a spindle to dispense. See pages 424-425

Cable Pulling

INTERNATIONAL

Tel: +1.815.397.7070
Fax: +1.815.397.9247

CANADA

Tel: 800.435.0786
Fax: 800.524.2853

USA

Tel: 800.435.0786
Fax: 800.451.2632

CABLE PULLING LUBRICANTS

Cable Pulling Lubricant Selection Guide



APPLICATION	Clear Lube™	Cable-Cream®	Cable-Gel®	Winter-Gel™
	Electrical or datacom use. Clear and colorless for easy cleanup.	Electrical use. Heavy Duty lubricant adheres well to cable without messy dripping.	Electrical or datacom use. Cleans up quickly, non-staining. Can be applied by hand or pump.	Electrical or datacom use. Will not freeze until 25°F. Can be applied by hand or pump.
Application Temperature Range (°F)	20°F - 190°F	20°F - 190°F	20°F - 190°F	-25°F - 190°F
Application Temperature Range (°C)	-6°C - 88°C	-6°C - 88°C	-6°C - 88°C	-31°C - 88°C
Minimum Storage Temperature	30° F/-1 C	30° F/-1 C	30° F/-1 C	-25° F/-31 C
Base	Polymer	Wax	Polymer	Polymer
Average Coefficient of Friction*	0.26	0.11	0.18	0.21
Color	Clear	Yellow	Blue/Green	Blue
COMPATIBILITY (Cable Type)				
Rubber	✓	✓	✓	✓
Neoprene	✓	✓	✓	✓
Nylon	✓	✓	✓	✓
PVC	✓	✓	✓	✓
High-density or cross linked polyethylene	✓	✓	✓	✓
Low-density polyethylene	✓	✓	✓	✓
Semiconducting jacket	✓	✓	✓	✓
Hypalon	✓	✓	✓	✓

* (IEEE 375-2 test procedure) kinetic coefficient of friction tested at 300 lb/ft sidewall bearing pressure

Cable Lubricant Quantity Chart

The following equation is a general guideline to determine the amount of cable lubricant to use for an average cable pull.

$$Q = 0.0015 \times L \times D$$

Where:

Q = Quantity of cable lubricant to use in gallons

L = Length of cable pull in feet

D = Diameter of conduit or duct in inches

If the following situations apply, consider using additional lubricant:

- The cable jacket is hard and/or cable is very stiff.
- The conduit is rough or dirty.
- There are many bends to pull through.
- The percentage of conduit filled by the cable is unusually high.
- The conduit is water filled.

SPECIFICATIONS	1"	2"	3"	4"
PULL LENGTH				
200'	0.3 gal.	0.6 gal.	0.9 gal.	1.2 gal.
300'	0.5 gal.	0.9 gal.	1.4 gal.	1.8 gal.
400'	0.6 gal.	1.2 gal.	1.8 gal.	2.4 gal.
600'	0.9 gal.	1.8 gal.	2.7 gal.	3.6 gal.
800'	1.2 gal.	2.4 gal.	3.6 gal.	4.8 gal.
1000'	1.5 gal.	3.0 gal.	4.5 gal.	6.0 gal.

N = NEW PRODUCT **R** = REPLACEMENT PART **A** = ACCESSORY

Cable Pulling

USA

Tel: 800.435.0786
Fax: 800.451.2632

CANADA

Tel: 800.435.0786
Fax: 800.524.2853

INTERNATIONAL

Tel: +1.815.397.7070
Fax: +1.815.397.9247

Cable-Cream® Cable Pulling Lubricant



- Advanced formula, light yellow cream makes pulling faster and easier.
- Compatible with all cable insulation types.
- Dries slowly to a thin, non-conductive, non-hardening residue.
- Adheres well to the cable without messy dripping. Reduces waste.
- Cleans up easily. Non-staining.
- Won't break down or separate after exposure to freezing cold or blistering heat.
- Environmentally safe/non-hazardous.

SPECIFICATIONS

Weight	CRM-Q - 2.3 lbs. (1 kg)
	CRM-5 - 42 lbs. (19.1 kg)
	CRM-1 - 9.5 lbs. (4.3 kg)
Viscosity	30,000 - 45,000 CPS
PH Range	7.0 - 8.0
Average COF	0.11

CAT. NO.	UPC NO.	DESCRIPTION
CRM-Q	35207	Cable-Cream One Quart Squeeze Bottle (.95 l)
CRM-1	35208	Cable-Cream One Gallon (3.79 l)
CRM-5	35209	Cable-Cream 5 Gallons (18.93 l)

Cable-Gel® Cable Pulling Lubricant



- Polymer-based, no silicon lubricant offers lower friction and easier pulling.
- Compatible with all cable insulation types.
- Cleans up quickly. Non-staining.
- Higher lubricity than competitive products.
- Will not cement itself to the pipe.
- Dries slowly.
- Can be applied by hand or pump.
- Will not break down or separate after exposure to heat or cold.
- Environmentally safe/non-hazardous.

SPECIFICATIONS

Weight	GEL-Q - 2.3 lbs. (1 kg)
	GEL-1 - 8.5 lbs. (3.9 kg)
	GEL-5 - 45 lbs. (20.4 kg)
	GEL-55 - 498 lbs. (225.9 kg)
Viscosity	8,000 - 12,000 CPS
PH Range	7.0 - 8.0
Average COF	0.18

CAT. NO.	UPC NO.	DESCRIPTION
GEL-Q	35211	Cable-Gel One Quart Squeeze Bottle (.95 l)
GEL-1	35212	Cable-Gel One Gallon (3.79 l)
GEL-5	35213	Cable-Gel 5 Gallons (18.93 l)

Winter-Gel™ Cable Pulling Lubricant



- Winter-Gel will not freeze until -25° F (-31° C).
- Reduces friction for easy pulling.
- Compatible with all cable insulation types.
- Cleans up quickly and easily.
- High lubricity.
- Can be used all year long.
- Environmentally safe.

SPECIFICATIONS

Weight	WGEL-Q - 2.3 lbs. (1 kg)
	WGEL-1 - 9 lbs. (4.1 kg)
	WGEL-5 - 44 lbs. (20 kg)
Viscosity	10,000 - 14,000 CPS
PH Range	7.0 - 8.0
Average COF	0.21

CAT. NO.	UPC NO.	DESCRIPTION
WGEL-Q	35215	Winter-Gel Pulling Lube One Quart Squeeze Bottle (.95 l)
WGEL-1	35216	Winter-Gel Pulling Lube One Gallon (3.79 l)
WGEL-5	35217	Winter-Gel Pulling Lube 5 Gallons (18.93 l)

Clear Lube™



LISTED



- Designed for use within electrical or datacom cable pulls.
- Clear and colorless for quick, easy clean-up.
- Environmentally safe, non-hazardous, non-toxic and non-corrosive.
- Easy to apply either by hand, brush or pump.
- Polymer base with no silicon additives.
- Three-year shelf life with no deterioration in lubricant.

CAT. NO.	UPC NO.	DESCRIPTION
CLR-Q	10437	Clear Lube pulling lubricant, 1 quart (.95 l)
CLR-1	10438	Clear Lube pulling lubricant, 1 gallon (3.79 l)
CLR-5	10439	Clear Lube pulling lubricant, 5 gallon (18.93 l)

SPECIFICATIONS

Weight	CLR-Q - 2.3 lbs. (1.0 kg)
	CLR-1 - 7.6 lbs. (3.5 kg)
	CLR-5 - 44.8 lbs. (20.4 kg)
Viscosity	10,000 - 20,000 CPS
PH Range	6.0 - 8.0
Average COF	0.26

SWABS, BRUSHES, MANDRELS & SWIVELS

Lube Spreader Swab



- Spreads a coat of wire lubricant in duct before installation of cable.
- Cleans mud, dirt, and light debris from duct before pulling.
- Tapered shape permits bi-directional use.
- Will not damage inner walls of duct.

CAT. NO.	UPC NO.	DUCT SIZE		MAXIMUM DISK SIZE		MAXIMUM RATED CAPACITY		WEIGHT	
		INCH	mm	INCH	mm	LBS.	kN	LBS.	kg
16854	16854	2	50.8	1.75	44.5	4800	21.3	.5	.23
16856	16856	2.5	63.5	2.25	57.2	4800	21.3	.6	.27
16857	16857	3	76.2	2.75	69.9	4800	21.3	1.5	.68
16858	16858	3.5	88.9	3.25	82.6	4800	21.3	2.0	.91
16859	16859	4	102	3.75	95.3	4800	21.3	2.5	1.13
17370	17370	5	127	4.75	120.7	4800	21.3	3.5	1.59
17571	17571	6	152	5.75	146.1	4800	21.3	4.0	1.81

Cable Pulling

USA

Tel: 800.435.0786
Fax: 800.451.2632

CANADA

Tel: 800.435.0786
Fax: 800.524.2853

INTERNATIONAL

Tel: +1.815.397.7070
Fax: +1.815.397.9247



Wire Duct Brush



- Flat steel bristles for maximum cleaning of sand, grit and light obstructions from duct.
- Pulling eye on one end and smaller twisted eye on the other end for tailing line allows bi-directional use.
- Can be pulled to loosen dried material before using mandrels or spreader swabs.

CAT. NO.	UPC NO.	DUCT SIZE		MINIMUM DIAMETER		MAXIMUM RATED CAPACITY		WEIGHT	
		INCH	mm	INCH	mm	LBS.	kN	LBS.	kg
39274	39274	2	50.8	1.87	47.5	200	.89	.83	.38
39276	39276	2.5	63.5	2.38	60.5	200	.89	.83	.38
39278	39278	3	76.2	2.87	72.9	200	.89	.83	.38
39280	39280	3.5	88.9	3.38	85.9	200	.89	.90	.41
39282	39282	4	102	3.87	98.3	200	.89	.95	.43
39284	39284	5	127	4.87	123.7	200	.89	1.15	.52
39286	39286	6	152	5.87	149.1	200	.89	1.28	.58

Flexible Mandrel



- Useful for cleaning out mud, dirt, and light obstacles from ducts before installation of cable.
- Can be used around tight bends due to convex contacts between disks.
- Tapered profile allows pulling in either direction. Pulling eyes on both ends.
- Polyurethane disks do not damage inner walls of duct.

CAT. NO.	UPC NO.	DUCT SIZE		MAXIMUM DISK SIZE		MAXIMUM RATED CAPACITY		WEIGHT	
		INCH	mm	INCH	mm	LBS.	kN	LBS.	kg
39265	39265	2	50.8	1.88	47.7	2330	10.3	1	.45
39263	39263	2.5	63.5	2.19	55.6	2330	10.3	1	.45
39261	39261	3	76.2	2.81	71.4	2330	10.3	1.5	.68
39259	39259	3.5	88.9	3.25	82.5	4800	21.3	3.5	1.59
39257	39257	4	102	3.75	95.3	4800	21.3	4.5	2.04
39255	39255	5	127	4.69	119.1	4800	21.3	6	2.72
39288	39288	6	152	5.81	147.5	4800	21.3	8.5	3.85

Rope-to-Swivel Connectors



- Rope-to-swivel connectors connect the cable pulling rope, up to 1" (254 mm) in diameter, to the pulling swivel.
- Makes connecting the pulling rope and the pulling swivel easier.
- Connectors feature a removable sheave for rope eye.
- Select the connector with a maximum rated capacity that meets or exceeds the cable puller's maximum pulling force.

CAT. NO.	UPC NO.	MAX. RATED CAPACITY IN CONDUIT		MAX. RATED CAPACITY OVERHEAD		DIAMETER		LENGTH		"E"		"F"		USE ON SWIVEL
		LBS.	kN	LBS.	kN	IN.	mm	IN.	mm	IN.	mm	IN.	mm	
39905	39905	5,000	22.2	3,000	13.3	2	50.8	4-11/16	119	7/16	11.12	13/32	10.32	39107
39904	39904	7,000	31.1	4,200	18.6	2	50.8	4-11/16	119	1/2	12.7	1/2	12.7	39108
39903	39903	10,000	44.4	6,000	26.6	2	50.8	4-11/16	119	9/16	14.3	5/8	15.9	39109
39902	39902	10,000	44.4	6,000	26.6	2	50.8	4-11/16	119	11/16	17.5	11/16	17.5	39110

CAT. NO.	UPC NO.	DESCRIPTION
39849	39849	Ⓡ Sheave
39850	39850	Ⓡ Sheave Pin

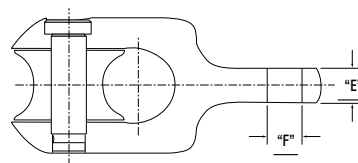

Swivels

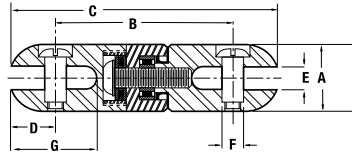

- Helps eliminate winding and tangling of rope and cable during pull.
- Connects grip and pulling rope.
- All stainless steel body construction.
- Efficient thrust and roller bearing construction allows smooth rotation, even under full load.
- Clevis pins are "shoulder bolt" style, so load on both sides of clevis is taken on the shoulder, not on the thread.
- Select the swivel with a maximum rated capacity that meets or exceeds the cable puller's maximum pulling force.

CAT. NO.	UPC NO.	MAXIMUM RATED CAPACITY		A DIAMETER		B		C		D		E		F DIAMETER		G		WEIGHT		REPLACEMENT* PIN KIT UPC NO.
		LBS.	kN	INCH	mm	INCH	mm	INCH	mm	INCH	mm	INCH	mm	INCH	mm	INCH	mm	LBS.	kg	
39106	39106	2,250	11.1	7/8	22.2	2-5/8	66.7	3-1/2	88.9	7/16	11.1	3/8	9.5	5/16	7.9	31/32	24.6	.4	.16	39112
39107	39107	5,000	22.2	1-1/4	31.8	3-1/16	77.8	4-1/8	104.5	17/32	13.5	1/2	12.7	13/32	10.3	1-9/32	32.5	1.0	.45	39113
39108	39108	7,000	31.1	1-3/8	34.9	3-9/32	83.3	4-17/32	115.1	5/8	15.9	9/16	14.3	1/2	12.7	1-3/8	34.9	1.0	.45	39114
39109	39109	10,000	44.4	1-5/8	41.3	3-15/16	100	5-7/16	138.1	3/4	19.1	5/8	15.9	5/8	15.9	1-23/32	43.7	2.0	.91	39115
39110	39110	15,000	66.7	2	50.8	4-11/16	119.1	6-9/16	166.7	15/16	23.8	3/4	19.1	11/16	17.5	2	50.8	4.0	1.81	39116
39111	39111	25,000	111.2	2-3/8	60.3	5-11/16	144.5	8-7/16	214.3	1-3/16	30.2	1	25.4	7/8	22.2	2-25/32	70.6	7.0	3.18	39117

* Replacement Pin Kits contain two (2) Replacement Pins

Breakaway Swivels

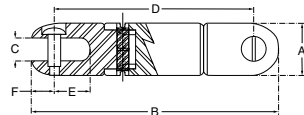
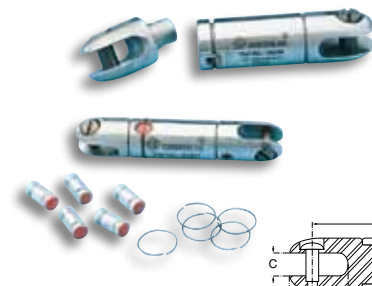

- Acts as a mechanical fuse, breaking away at a preset load to prevent damage to expensive cable.
- Breakaway pins can be replaced to change breakaway values.

BREAKAWAY PIN KITS

CAT. NO.	UPC NO.	BREAKING POINT LBS.	BREAKING POINT kN	COLOR CODE	USE WITH
39294	39294	200 lbs.	0.9 kN	WHITE	
39295	39295	400 lbs.	1.8 kN	YELLOW	39290
39296	39296	600 lbs.	2.7 kN	ORANGE	5/8" Swivel
39297	39297	675 lbs.	3.0 kN	BLACK	
39302	39302	200 lbs.	0.9 kN	WHITE	
39303	39303	400 lbs.	1.8 kN	YELLOW	39298
39304	39304	600 lbs.	2.7 kN	ORANGE	7/8" Swivel
39306	39306	800 lbs.	3.6 kN	GREY	
39308	39308	1000 lbs.	4.4 kN	RED	

BREAKAWAY SWIVEL BODY ONLY

CAT. NO.	UPC NO.	A		B		C		D		E		F	
		INCH	mm	INCH	mm	INCH	mm	INCH	mm	INCH	mm	INCH	mm
39290	39290	5/8	15.9	3-7/32	81.8	9/32	7.1	2-23/32	69.1	7/16	11.1	1/4	6.4
39298	39298	7/8	22.2	4-7/32	107.2	3/8	9.5	3-11/32	84.9	17/32	13.5	5/16	7.9

* Pins sold in bags of 10 only. * Breakaway values are ±15%.

Rope Clevis

For forged eye grips

For forged eye grips



For flexible eye grips



- Removable bolt and rope sheave.
- Removable grip eye bolt.
- Select the clevis with a rating that meets or exceeds the cable puller's maximum pulling force.
- Removable sheave for rope eye.

CAT. NO.	UPC NO.	DESCRIPTION
578	31910	Rope Clevis
579	31905	Rope Clevis
678	19524	Rope Clevis

SPECIFICATIONS

	Maximum Rated Capacity	Weight	Length	Width	Inside Diameter
578	6,500 lbs. (28.9 kN)	0.9 lbs. (408 g)	3.0" (76 mm)	1.406" (36 mm)	1.25" (32 mm)
579	10,000 lbs. (44.4 kN)	1.3 lbs. (589 g)	3.5" (89 mm)	1.84" (47 mm)	1.5" (38 mm)
678	6,500 lbs. (28.9 kN)	1.3 lbs. (589 g)	3.5" (89 mm)	1.75" (44 mm)	0.94" (24 mm)

N = NEW PRODUCT **R** = REPLACEMENT PART **A** = ACCESSORY



GRIPS

Set Screw Clamp Pulling Grips

Cable Pulling

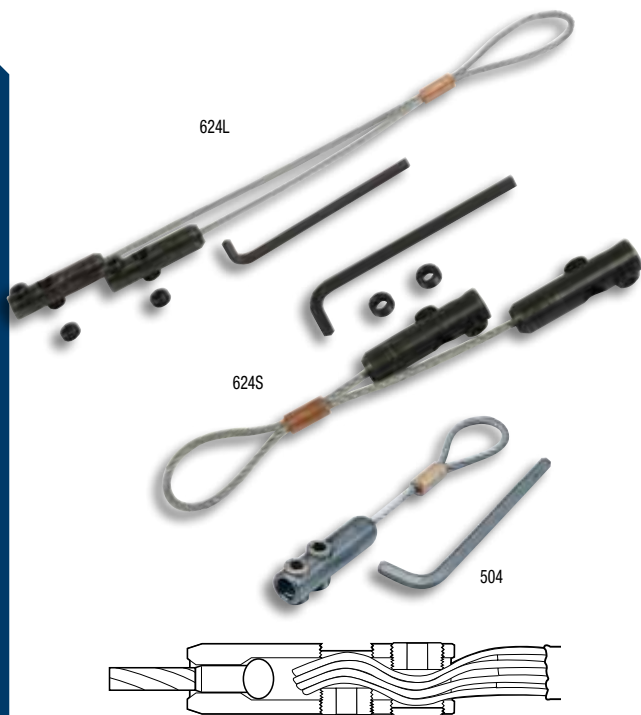

Each grip has two opposed set screws that provide positive locking. Openings in wire grip should be 50% filled with wire to assure slip-proof grip.

- Use to pull in 2" (50.8 mm) or larger conduit.
- Type of pulls: heavy, long runs. (629)
- Type of pull: light and medium. (504)
- Type of grip: Flexible eye 1/4" (6.4 mm-629) (6.3 mm-504) diameter galvanized steel aircraft cable connected to 2 cable receptacles with 5/8" (15.9 mm) diameter opening and 2 clamping set screws.
- Select pulling grips with a maximum-rated capacity that meets or exceeds the cable puller's maximum pulling force.
- Minimum cable diameter is 3/8".

CAT. NO.	UPC NO.	DESCRIPTION
504	23665	Set Screw Clamp-Type Pulling Grip
629	31855	Pulling Grip with Clevis includes 624S, 624L and 678 clevis - 4 clamp
624	31908	Pulling Grip includes 624S and 624L - 2 clamp each
624S	31866	Short Pulling Grip - 2 Clamp
624L	31867	Long Pulling Grip - 2 Clamp
51208	51208	R Grip Allen Wrench
52352	52352	R Grip Set Screw (2 per clamp), 629 and 624 - 8 for each grip 624L and 624S - 4 for each grip.

SPECIFICATIONS

Maximum Rated Capacity	Weight
504 - 6,500 lbs. (28.9 kN)	504 - 5 lbs. (2.3 kg)
629 - 6,500 lbs. (28.9 kN)	629 - 5 lbs. (2.3 kg)
624 - 6,500 lbs. (28.9 kN)	624 - 3.5 lbs. (1.5 kg)
624S - 3,250 lbs. (14.5 kN)	624S - 2 lbs. (.9 kg)
624L - 3,250 lbs. (14.5 kN)	624L - 2.1 lbs. (1 kg)

SPECIFICATIONS

Capacity	1,750 lbs. (7.7 kN)
Weight	1.2 lbs. (.5 kg)
Size	Receptacle - 5/8" (15.9 mm)

Cable Preparation Instructions for Set Screw Clamp-Type Pulling Grips

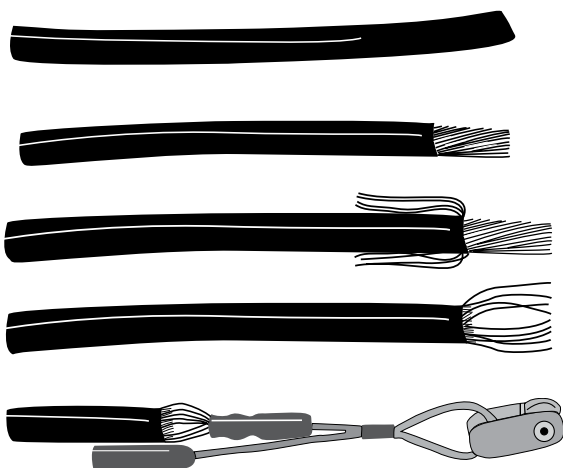

Strip cable approximately 3" (76 mm) of insulation off the end of the cable to be pulled. **NOTE:** The grip head should not be more than 60% filled nor less than 40% filled to assure that the set screw does not project above the surface of the grip body when the set screws are tightened down.

The central core should be clipped away and the outer strands used in the grip head.

Using the Allen Wrench provided, back out the set screws far enough to accommodate the stripped cables.

Insert the bare wire strands into the grip head as far as they will go.

Tighten both set screws in each grip securely against the conductors.

CAUTION: If the set screws extend above the surface of the gripping head, damage to the conduit could result. To prevent this, wrap the head with electrical tape.

INTERNATIONAL

Tel: +1.815.397.7070
Fax: +1.815.397.9247

CANADA

Tel: 800.435.0786
Fax: 800.524.2853

USA

Tel: 800.435.0786
Fax: 800.451.2632

Pulling Grip Selection Guide

How to select correct pulling grip:

1. Select the type of grip needed.
2. Select the size of grip needed (see below).
3. Select a grip with maximum rated capacity that meets or exceeds the cable puller's maximum pulling force.

1. SELECT THE TYPE OF GRIP NEEDED.

GRIP TYPE	DESCRIPTION	TYPE OF EYE	SIZE RANGE DIA. INCHES (mm)	MAX. RATED CAPACITY – LBS. (kN)	USE TO PULL
Junior Grips	Single weave galvanized steel mesh	Flexible	.19-1.24 (4.8-31.5)	708 (3.5)	In conduit or tray – Building wire by hand.
Light Duty Grips	Single weave galvanized steel mesh	Flexible	.50-3.99 (12.7-101.3)	2940 (13.1)	In conduit or tray – Light-duty applications, short easy runs.
T-Type Grips	Double weave galvanized steel mesh	Flexible	.50-3.99 (12.7-101.3)	6200 (27.6)	In conduit or tray – Medium-duty applications
K-Type Grips	Double weave galvanized steel mesh	Rotating forged	.50-6.99 (12.7-177.5)	9600 (42.7)	In conduit or tray – Heavy-duty applications, long hard runs.
Multiple Strength Grips	Triple to double to single weave galvanized steel mesh	Rotating forged	.25-3.99 (6.4-101.3)	9600 (42.7)	Overhead transmission lines – Bare or insulated conductors, wire rope.
Slack Grips Rod Closing	Double weave galvanized steel mesh – rod closing – offset eye	Flexible	.50-3.99 (12.7-101.3)	2400 (10.7)	Where end of conductor is not available. Can be pulled straight only, rod will not flex.

2. SELECT THE SIZE OF GRIP NEEDED.

After determining the type of grip needed, measure the diameter of the cable being pulled. If pulling more than one cable "of the same diameter," refer to chart below for required grip diameter range. If pulling more than one cable "of different diameters," bundle cables together, measure the circumference

and refer to the chart on bottom of this page for required grip diameter range. Once the cable diameter or required grip diameter is determined, refer to individual chart for type of grip chosen to locate Catalog/UPC number.

CABLES WITH THE SAME DIAMETER IN ONE GRIP*

2 CABLES DIA. EACH IN./(mm)	3 CABLES DIA. EACH IN./(mm)	4 CABLES DIA. EACH IN./(mm)	5 CABLES DIA. EACH IN./(mm)	6 & 7 CABLES DIA. EACH IN./(mm)	8 CABLES DIA. EACH IN./(mm)	9 CABLES DIA. EACH IN./(mm)	REQUIRED GRIP DIAMETER IN./(mm)
.30-.38/(7.6-9.7)	.25-.31/(6.4-7.9)	.22-.27/(5.6-6.9)	.19-.24/(4.8-6.1)	.17-.22/(4.3-5.6)	.15-.19/(3.8-6.1)	.14-.18/(3.6-4.6)	.50-.61/(12.7-15.5)
.38-.44/(9.7-11.2)	.31-.36/(7.9-9.1)	.27-.31/(6.9-7.9)	.24-.29/(6.1-7.4)	.22-.26/(5.6-6.6)	.19-.23/(6.1-5.8)	.18-.21/(4.6-5.3)	.62-.74/(15.7-18.8)
.44-.59/(11.2-15.0)	.36-.49/(9.1-12.4)	.31-.42/(7.9-10.7)	.29-.38/(7.4-9.7)	.26-.34/(6.6-8.6)	.23-.31/(5.8-7.9)	.21-.28/(5.3-7.1)	.75-.99/(19.1-25.1)
.59-.75/(15.0-19.1)	.49-.63/(12.4-16.0)	.42-.54/(10.7-13.7)	.38-.48/(9.7-12.2)	.34-.43/(8.6-10.9)	.31-.39/(7.9-9.9)	.28-.35/(7.1-8.9)	1.00-1.24/(25.4-31.5)
.75-.90/(19.1-22.9)	.63-.76/(16.0-19.3)	.54-.65/(13.7-16.5)	.48-.58/(12.2-14.7)	.43-.52/(10.9-13.2)	.39-.46/(9.9-11.7)	.35-.42/(8.9-10.7)	1.25-1.49/(31.8-37.8)
.90-1.07/(22.9-27.2)	.76-.89/(19.3-22.6)	.65-.77/(16.5-19.6)	.58-.67/(14.7-17.0)	.52-.60/(13.2-15.2)	.46-.54/(11.7-13.7)	.42-.49/(10.7-12.4)	1.50-1.74/(38.1-44.2)
1.07-1.22/(27.2-31.0)	.89-1.02/(22.6-25.9)	.77-.88/(19.6-22.4)	.67-.77/(17.0-19.6)	.60-.69/(15.2-17.5)	.54-.62/(13.7-15.7)	.49-.56/(12.4-14.2)	1.75-1.99/(44.5-50.5)
1.22-1.53/(31.0-39.9)	1.02-1.28/(25.9-32.5)	.88-1.10/(22.4-27.9)	.77-.96/(19.6-24.2)	.69-.86/(17.5-21.8)	.62-.77/(15.7-19.6)	.56-.71/(14.2-18.00)	2.00-2.49/(50.8-63.2)
1.53-1.83/(38.9-46.5)	1.28-1.53/(32.5-38.9)	1.10-1.32/(27.9-33.5)	.96-1.16/(24.2-29.5)	.86-1.03/(21.8-26.2)	.77-.93/(19.6-23.6)	.71-.85/(18.0-21.6)	2.50-2.99/(63.5-75.9)
1.83-2.14/(46.5-54.4)	1.53-1.79/(38.9-45.5)	1.32-1.54/(33.5-39.1)	1.16-1.35/(29.5-34.3)	1.03-1.20/(26.2-30.5)	.93-1.08/(23.6-27.4)	.85-.99/(21.6-25.1)	3.00-3.49/(76.2-88.6)
2.14-2.44/(54.4-62.0)	1.79-2.05/(45.5-52.0)	1.54-1.76/(39.1-44.7)	1.35-1.54/(34.3-39.1)	1.20-1.37/(30.5-34.8)	1.08-1.24/(27.4-31.5)	.99-1.13/(25.1-28.7)	3.50-3.99/(88.9-101.3)
2.44-2.75/(62.0-69.9)	2.05-2.30/(52.0-58.4)	1.76-1.98/(44.7-50.3)	1.54-1.74/(39.1-44.2)	1.37-1.55/(34.8-39.4)	1.24-1.39/(31.5-35.3)	1.13-1.27/(28.7-32.3)	4.00-4.49/(101.6-114.0)
2.75-3.06/(69.9-77.7)	2.30-2.56/(58.4-65.0)	1.98-2.20/(50.3-55.9)	1.74-1.93/(44.2-49.0)	1.55-1.72/(39.4-43.7)	1.39-1.55/(35.3-39.4)	1.27-1.41/(32.3-35.8)	4.50-4.99/(114.3-126.7)

* Split grips require the next larger size.

MEASURE THE CIRCUMFERENCE OF THE WIRE BUNDLE

CIRCUMFERENCE RANGE		REQUIRED GRIP DIAMETER	
INCH	mm	INCH	mm
1.57- 1.95	39.9- 49.5	.50- .61	12.7- 15.5
1.95- 2.36	49.5- 59.9	.62- .74	15.8- 18.8
2.36- 3.14	59.9- 79.8	.75- .99	19.1- 25.1
3.14- 3.93	79.8- 99.8	1.00-1.24	25.4- 31.5
3.93- 4.71	99.8-119.6	1.25-1.49	31.8- 37.8
4.71- 5.50	119.6-139.7	1.50-1.74	38.1- 44.2
5.50- 6.28	139.7-159.5	1.75-1.99	44.5- 50.5
6.28- 7.85	159.5-199.4	2.00-2.49	50.8- 63.2
7.85- 9.42	199.4-239.3	2.50-2.99	63.5- 75.9
9.42-11.00	239.3-279.4	3.00-3.49	76.2- 88.6
11.00-12.57	279.4-319.3	3.50-3.99	88.9-101.3
12.57-14.14	319.3-359.2	4.00-4.49	101.6-114.0
14.14-15.71	359.2-399.0	4.50-4.99	114.3-126.7



Basket-Type Pulling Grip Sets



- Handy set gives you the size range you need.
- Have the correct grip on the job and save time.

CAT. NO.	UPC NO.	DESCRIPTION
30758	30758	Building Wire Junior Grip Set - diameter range .25" - 1.24" (6.4 - 31.5 mm). Consists of 30588, 30590, 30592, and 30594, 30584, 30586.
597	31482	T-Type Grip Set - diameter range .75" - 1.99" (19 - 50.5 mm). Consists of 30576, 30578, and 31010.
598	31483	T-Type Grip Set - diameter range 1.50" - 2.99" (38.1 - 75.9 mm). Consists of 31010, 30580 and 31012.
599	31484	T-Type Grip Set - diameter range .75" - 2.99" (19 - 75.9 mm). Consists of 30576, 30578, 31010, 30580 and 31012.

SPECIFICATIONS

Capacity	30758 - (2) #14 to 4-1/0, .25" - 1.24" (6.4 - 31.5 mm) diameter
	597 - 3-1/0 to 250 MCM, .75" - 1.99" (1.9 - 50.5 mm) diameter
	598 - 3-350 MCM to 3-750 MCM, 1.50" - 2.99" (38.1 - 75.9 mm) diameter
	599 - 3-1/0 to 3-750 MCM, .75" - 2.99" (1.9 - 75.9 mm) diameter
Weight	30758 - 1.2 lbs. (.5 kg) 597 - 6 lbs. (2.7 kg)
	598 - 9.9 lbs. (4.5 kg) 599 - 13 lbs. (5.9 kg)

Junior Basket-Type Pulling Grips

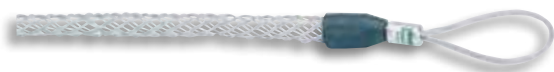

- Use to pull in: conduit or tray.
- Type of pulls: building wire manually.
- Type of grip: single weave galvanized steel mesh with flexible pulling eye.
- Select the grip with a maximum rated capacity that meets or exceeds the cable puller's maximum pulling force.

CAT. NO.	UPC NO.	CABLE DIAMETER RANGE		MAXIMUM RATED CAPACITY		EYE LENGTH		MESH LENGTH	
		INCH	mm	LBS.	kN	INCH	mm	INCH	mm
30596	30596	.19 - .24	4.8 - 6.1	80	.3	3-1/4	82.6	4-1/4	108
30584	30584	.25 - .36	6.2 - 9.1	90	.4	3-1/4	82.6	4-1/4	108
30586	30586	.37 - .49	9.2 - 12.6	180	.8	3-3/4	95.3	7	177.8
30588	30588	.50 - .61	12.7 - 15.50	260	1.1	4-1/4	108	8-1/2	215.9
30590	30590	.62 - .74	15.6 - 18.9	390	1.7	5	127	10	254
30592	30592	.75 - .99	19 - 25.3	560	2.4	5-3/4	146	10	254
30594	30594	1.00 - 1.24	25.4 - 31.5	780	3.4	6-1/2	165.1	11-1/2	292.1

Light-Duty Basket-Type Pulling Grips



- Use to pull in: conduit or tray.
- Type of pulls: light-duty, short, easy runs.
- Type of grip: single weave galvanized steel mesh with flexible pulling eye.
- Select the grip with a maximum rated capacity that meets or exceeds the cable puller's maximum pulling force.

CAT. NO.	UPC NO.	CABLE DIAMETER RANGE		MAXIMUM RATED CAPACITY		EYE LENGTH		MESH LENGTH	
		INCH	mm	LBS.	kN	INCH	mm	INCH	mm
STANDARD									
30536	30536	.50 - .61	12.7 - 15.5	560	2.5	5	127	16	406.4
30538	30538	.62 - .74	15.6 - 18.9	560	2.5	5	127	16	406.4
30540	30540	.75 - .99	19.0 - 25.3	800	3.5	6	152.4	20	508
30542	30542	1.00 - 1.24	25.4 - 31.5	1360	6	7	177.8	20	508
30544	30544	1.25 - 1.49	31.6 - 38	1360	6	7	177.8	21	533.4
30546	30546	1.50 - 1.99	38.1 - 50.7	1360	6	8	203.2	23	584.2
30548	30548	2.00 - 2.49	50.8 - 63.4	1700	7.5	9	228.6	25	635
30550	30550	2.50 - 2.99	63.5 - 76.1	2120	9.4	9	228.6	27	685.8
30552	30552	3.00 - 3.49	76.2 - 88.8	2940	13	10	254	30	762
30554	30554	3.50 - 3.99	88.9 - 101.3	2940	13	10	254	32	812.8

T-Basket-Type Pulling Grips



- Use to pull in: conduit or tray.
- Type of pulls: medium-duty.
- Type of grip: double weave galvanized steel mesh with flexible pulling eye.
- Select the grip with a maximum rated capacity that meets or exceeds the cable puller's maximum pulling force.

CAT. NO.	UPC NO.	CABLE DIAMETER RANGE		MAXIMUM RATED CAPACITY		EYE LENGTH		MESH LENGTH		
		INCH	mm	LBS.	kN	INCH	mm	INCH	mm	
SHORT										
30558	30558	.50 - .61	12.7 - 15.5	900	4	8	203.2	21	533.4	
30560	30560	.62 - .74	15.6 - 18.9	1120	4.9	8	203.2	24	610	
30562	30562	.75 - .99	19.0 - 25.3	1360	6	9	228.6	24	610	
30564	30564	1.00 - 1.49	25.4 - 38.0	1920	8.7	9	228.6	24	610	
30566	30566	1.50 - 1.99	38.1 - 50.7	3280	14.5	11	279.4	24	610	
30568	30568	2.00 - 2.49	50.8 - 63.3	3700	16.4	12	304.8	24	610	
30570	30570	2.50 - 2.99	63.5 - 76.1	4900	21.7	12	304.8	24	610	
30572	30572	3.00 - 3.49	76.2 - 88.8	4900	21.7	14	355.6	24	610	
30574	30574	3.50 - 3.99	88.9 - 101.3	6200	27.5	14	355.6	26	660.4	
STANDARD										
30576	30576	.75 - .99	19.0 - 25.3	1360	6	9	228.6	36	914.4	
30578	30578	1.00 - 1.49	25.4 - 38.0	1920	8.7	9	228.6	36	914.4	
31010	31010	1.50 - 1.99	38.1 - 50.7	3280	14.5	11	279.4	36	914.4	
30580	30580	2.00 - 2.49	50.8 - 63.3	3700	16.4	12	304.8	36	914.4	
31012	31012	2.50 - 2.99	63.5 - 76.1	4900	21.7	12	304.8	36	914.4	
30582	30582	3.00 - 3.49	76.2 - 88.8	4900	21.7	14	355.6	36	914.4	
31014	31014	3.50 - 3.99	88.9 - 101.3	6200	27.5	14	355.6	40	1016	

K Basket-Type Pulling Grips

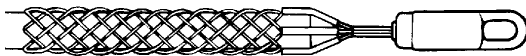

- Use to pull in: conduit or tray.
- Type of pulls: heavy-duty, long, hard runs.
- Type of grip: double-weave galvanized steel mesh with forged steel swivel eye.
- Select the grip with a maximum rated capacity that meets or exceeds the cable puller's maximum pulling force.

CAT. NO.	UPC NO.	CABLE DIAMETER RANGE		MAXIMUM RATED CAPACITY		EYE LENGTH		MESH LENGTH		ROTATING EYE DIA.	
		INCH	mm	LBS.	kN	INCH	mm	INCH	mm	INCH	mm
STANDARD											
30442	30442	.50 - .61	12.7 - 15.5	1120	4.9	5	127	16	406.4	7/8	22.2
30998	30998	.62 - .74	15.6 - 18.9	1360	6	5	127	16	406.4	7/8	22.2
30460	30460	.75 - .99	19.0 - 25.3	1920	8.5	6	152.4	32	812.8	1	25.4
31000	31000	1.00 - 1.49	25.4 - 38.0	3280	14.5	7	177.8	33	838.2	1-3/8	34.9
30462	30462	1.50 - 1.99	38.1 - 50.7	3280	14.5	7	177.8	34	863.6	1-3/8	34.9
31002	31002	2.00 - 2.49	50.8 - 63.3	5440	24.1	9	228.6	36	914.4	1-5/8	41.2
30464	30464	2.50 - 2.99	63.5 - 76.1	6600	29.3	10	254	38	965.2	1-7/8	47.6
31004	31004	3.00 - 3.49	76.2 - 88.8	8200	36.5	10	254	39	990.6	1-7/8	47.6
30466	30466	3.50 - 3.99	88.9 - 101.5	9600	42.7	10	254	41	1041.4	1-7/8	47.6
31006	31006	4.00 - 4.49	101.6 - 114.2	9600	42.7	10	254	42	1066.8	1-7/8	47.6
30468	30468	4.50 - 4.99	114.3 - 126	9600	42.7	10	254	58	1473.2	1-7/8	47.6
30470	30470	5.00 - 5.99	127 - 152.3	9600	42.7	10	254	60	1524	1-7/8	47.6

NOTE: Rope is a very critical link in the cable pulling system. See page 166 for proper pulling rope selection.



Multiple Strength Basket-Type Pulling Grips with Rotating Forged Eye



- Use to pull overhead transmission lines, bare or insulated conductors and wire rope.
- Type of pulls: heavy-duty, long distance.
- Triple, to double, to single weave galvanized steel mesh with forged steel swivel eye
- Color coded for easy size identification.
- Select the grip with a maximum rated capacity that meets or exceeds the cable puller's maximum pulling force.

CAT. NO.	UPC NO.	CABLE DIAMETER RANGE		MAXIMUM RATED CAPACITY		COLOR CODE	EYE LENGTH		MESH LENGTH		ROTATING EYE DIAMETER	
		INCH	mm	LBS.	kN		INCH	mm	INCH	mm	INCH	mm
30474	30474	.25 - .49	12.7 - 15.5	1360	6	Dark Green	5	127	26	660.4	7/8	22.3
30476	30476	.50 - .74	15.6 - 18.9	2000	8.8	Brown	6	152.4	32	812.8	1	25.4
30478	30478	.75 - .99	19.0 - 25.3	2880	12.8	Light Blue	6	152.4	41	1041.4	1	25.4
30480	30480	1.00 - 1.24	25.4 - 31.5	4920	21.8	Gold	8	203.2	52	1320.8	1-3/8	34.9
30482	30482	1.25 - 1.49	31.6 - 38.0	6120	27.2	Black	8	203.2	56	1422.4	1-5/8	41.2
30484	30484	1.50 - 1.74	38.1 - 44.3	6120	27.2	Red	9	228.6	60	1524.0	1-7/8	47.6
30486	30486	1.75 - 2.24	44.4 - 56.9	9600	42.7	Dark Blue	10	254	70	1778.0	1-7/8	47.6
30502	30502	2.00 - 2.49	50.8 - 63.4	9600	42.7	Yellow	10	254	50	1270	1-7/8	47.6
30504	30504	2.50 - 2.99	63.5 - 76.1	9600	42.7	Orange	10	254	52	1320.8	1-7/8	47.6
30506	30506	3.00 - 3.49	76.2 - 88.8	9600	42.7	Aluminum	10	254	54	1371.6	1-7/8	47.6
30508	30508	3.50 - 3.99	88.9 - 101.3	9600	42.7	Light Green	10	254	56	1422.4	1-7/8	47.6

NOTE: Rope is a very critical link in the cable pulling system. See page 166 for proper pulling rope selection.

Split Mesh Rod Closing Basket-Type Slack Pulling Grips

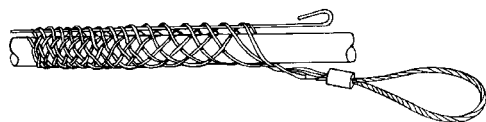

- Use to pull when the end of the conductor is not available.
- Type of pulls: light and straight. The rod will not flex around bends.
- Single weave galvanized steel mesh with rod closing and an offset flexible eye.
- Select the grip with a maximum rated capacity that meets or exceeds the cable puller's maximum pulling force.

CAT. NO.	UPC NO.	CABLE DIAMETER RANGE		MAXIMUM RATED CAPACITY		EYE LENGTH		MESH LENGTH	
		INCH	mm	LBS.	kN	INCH	mm	INCH	mm
30658	30658	.50 - .61	12.7 - 15.50	300	1.3	7	177.8	6	152.4
31024	31024	.62 - .74	15.6 - 18.9	360	1.6	7	177.8	8	203.2
30660	30660	.75 - .99	19 - 25.3	440	1.9	7	177.8	10	254
31026	31026	1.00 - 1.24	25.4 - 31.5	680	3	8	203.2	12	304.8
30662	30662	1.25 - 1.49	31.6 - 38.0	900	4	8	203.2	14	355.6
31028	31028	1.50 - 1.74	38.1 - 44.3	1160	5.1	9	228.6	15	381
30664	30664	1.75 - 1.99	44.4 - 50.7	1520	6.7	10	254	16	406.4
31030	31030	2.00 - 2.49	50.8 - 63.4	1800	8	10	254	19	482.6
30666	30666	2.50 - 2.99	63.5 - 76.1	2200	9.7	10	254	20	508
31032	31032	3.00 - 3.49	76.2 - 88.8	2400	10.6	12	304.8	21	533.4
30668	30668	3.50 - 3.99	88.9 - 101.3	2400	10.6	12	304.8	24	610

NOTE: Rope is a very critical link in the cable pulling system. See page 166 for proper pulling rope selection.